

VENTILATION UNITS PICHLER SERIES

**VENTILATION
UNITS**



 **PICHLER**

Systematic ventilation.





Highly efficient ventilation systems

We are immersed in it every day, invisible yet so vital to our well-being – the air without which we cannot live. We spend about two thirds of the time indoors. We may therefore expect healthy, fresh air at home and at work as naturally as we do clean water. Comfort depends largely on the quality of the air. This is exactly where our ventilation systems are needed, since the right combination of temperature, humidity, freshness and cleanliness are paramount to our true well-being.

Our business focuses largely on multi-storey buildings. We were the first supplier of large units certified for regulated aeration and ventilation by the Passive House Institute in Darmstadt.

Our range comprises central systems supplying several apartments or offices from a central ventilation unit and decentralised systems with a compact unit for each location.

Furthermore, our PICHLER school ventilation systems ensure an excellent indoor climate that promotes the health and performance of both students and teachers. Depending on your basic situation, whether your project concerns a new-build or a renovation, we offer the ideal ventilation technology solution for every application and any size of building: from small-sized nursery schools to the university campus, including multi-storey school buildings.



Content

Highly efficient ventilation systems	3
PICHLER standard unit series	6
Control and regulation	7
Operation	9
Components and accessories	10
PICHLER standard unit series	14
ErP application areas	14
Overview of unit designations	16
LG 100	20
LG 150	21
LG 350 & LG 450	22
LG 740	23
LG 750 IN	24
LG 750 K WF/DINT	25
LG 900 KN DE	26
LG 1000 IN	27
LG 1000 K WF/DINT	28
LG 1000 KN WF/DINT	29
LG 1000 SKDE	30
LG 1000 SKS	31
LG 1400	32
LG 1800 IN	33
LG 1800 K WF/DINT	34
LG 1800 KN WF/DINT	35
LG 2500 IN	36
LG 2500 WF/DINT	37
LG 2500 N WF/DINT	38
LG 3200	39
LG 4000 IN	40
LG 4000 WF/DINT	41
LG 6000 IN	42
LG 6000 WF/DINT	43
PICHLER system components	44
PICHLER components and accessories	46
PICHLER original filters	48
Complete solutions	50
Notes	51

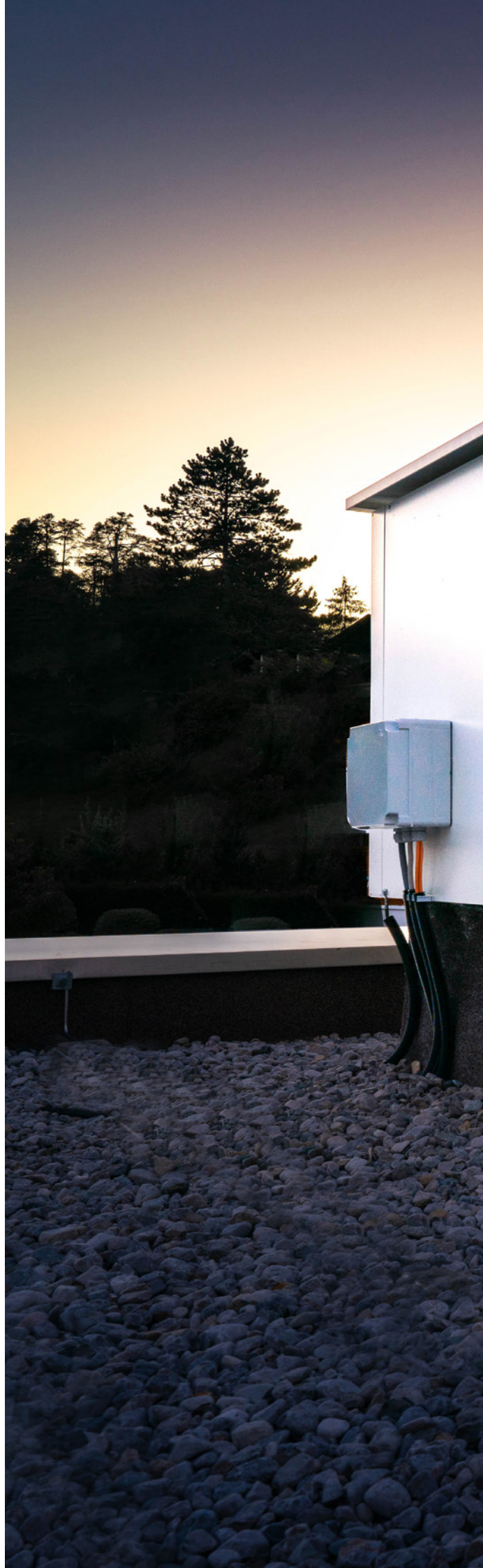

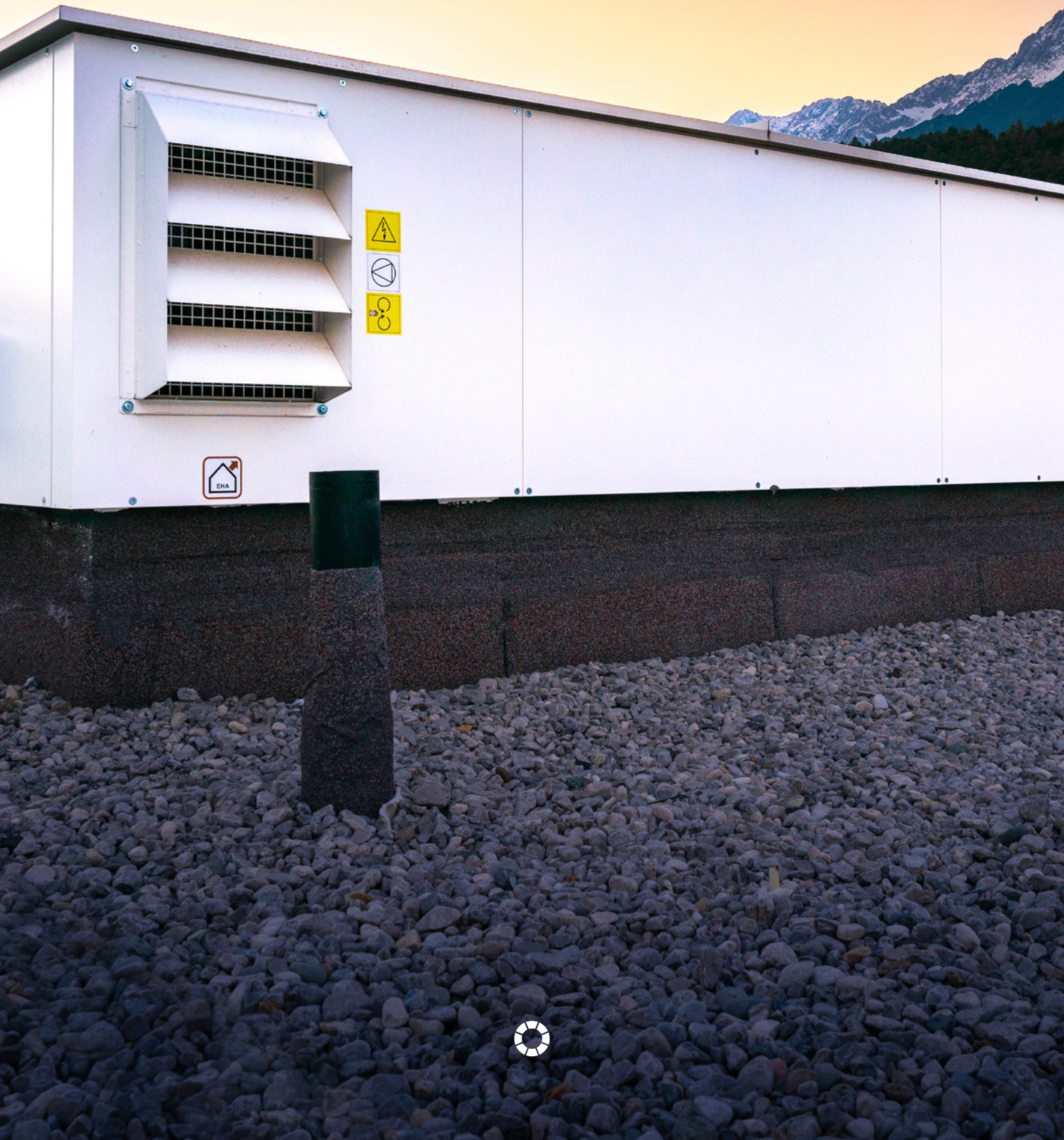

PICHLER standard unit series

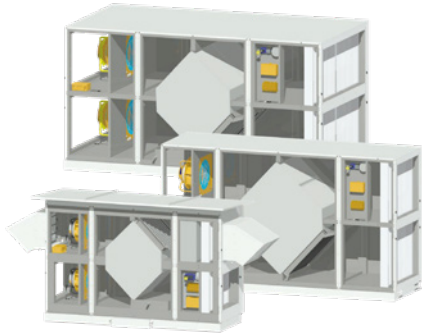

DESIGN VARIANTS & INSTALLATION

Our ventilation units for regulated aeration and ventilation of buildings of all kinds are available in various designs – in compact or module version with air volumes of up to approx. 8,000 m³/h.

The ventilation units from Austrian in-house production consist of a heat-insulated housing of galvanised steel sheet, powder-coated on the outside in RAL 9010, and are suited for free-standing or ceiling installation as weatherproof ventilation unit or for indoor installation, and as version integrated into the roof. PICHLER module ventilation units contain combinable modules, from pre-heater and post-heater batteries, water-electrical, including cooling and combi heater batteries as well as sound absorber modules and humidifying units.

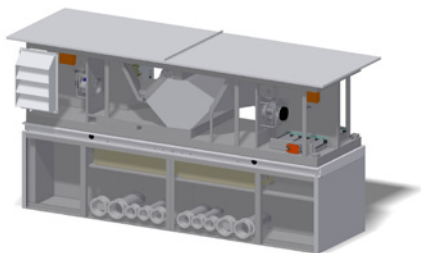

BASE FOR VENTILATION UNITS INTEGRATED INTO THE ROOF

- Base in panel design with a heat transition coefficient $< 0.3 \text{ W/m}^2\text{K}$
- Thermal decoupling from building shell
- Openings for air ducts freely selectable
- Variable base height (depending on roof structure)
- Weather protection cover



HEAT RECOVERY

ALUMINIUM COUNTERFLOW HEAT EXCHANGERS (T VERSION)

In the T version (temperature change $> 85\%$), the ventilation units contain a highly efficient heat recovery system with air/air aluminium counterflow heat exchangers.

ENTHALPY EXCHANGERS WITH HUMIDITY RECOVERY (F VERSION)

In the F version, the ventilation units feature an enthalpy exchanger with humidity recovery.



SUPPLY AIR AND EXTRACT AIR FAN WITH EC TECHNOLOGY

Energy-saving radial fans with quiet EC motor technology



ORIGINAL PICHLER FILTERS

Original PICHLER filters are tested and classified in accordance with ISO 16890. We offer you a wide range of different air filters from the four ISO 16890 groups: ePM1, ePM2.5, ePM10 and Coarse.



Control and regulation



PICHLER AIR2 CONTROL AND REGULATION SYSTEM IN CONNECTION WITH THE PI-HMI-35T CONTROL UNIT

The Pichler control and regulation system comprises all required components for controlling fans, heat exchangers, drives, actuators, electrical and water-based heating and cooling systems in modern ventilation units. State-of-the-art bus technology allows for the internal data exchange between the system components. The control system can be optionally connected to a large variety of commercially available bus systems. The master contains all system interfaces, a high-performance processor unit as well as an optional web server. Different access levels matching the corresponding user groups can be defined by the administrator via a multi-level user interface. The regulation system can be operated with the PI-HMI-35 T touch display. All peripheral devices are connected to the master module via a bus line. This makes it possible to provide a very simple system wiring structure while maintaining full control of all system units. This exceptional solution enables us to implement the processes of installing, approving and commissioning the system with particular efficiency. The ventilation unit can be assembled in the plant, including all internal installation and wiring processes.



CONTROL

As a standard, our ventilation units come with a constant volume flow controller and three adjustable ventilation levels. Expansion options to implement constant pressure control or a Pichler system optimizer control are optionally available.



MODBUS/KNX GATEWAY

The Modbus/KNX gateway provides for the connection of a ventilation unit to a KNX bus system. In this case, the gateway serves as a connective link between the two bus systems. Note that the gateway always acts as the master for the Modbus. On the KNX side, however, it responds like a standard KNX TP-1 unit. This makes it possible to centrally control and monitor the ventilation unit using a KNX system.

A "Config Tool" (a DCA or Device Configuration App) is provided to facilitate configuration of the ETS. With this, it is possible to adopt any existing configurations for the gateway.



Control and regulation



DEMAND-BASED VENTILATION CONTROL

The unit can be optionally expanded by adding CO₂, humidity and indoor temperature sensors, providing for demand-controlled ventilation operation. The ventilation unit will automatically increase or reduce the air volumes depending on the quality of the indoor air.



DUCT TEMPERATURE SENSOR ETF 598B-3A

Sensor type: PT1000
Protection class: IP67
Cable length: 3 m
with mounting flange



ROOM TEMPERATURE SENSOR

PT1000 sensor in the surface-mounted housing



CO₂ SENSOR

CO₂ sensor in the surface-mounted housing, suitable for wall mounting, for demand-based regulation of the volume flow.



MULTI-FUNCTIONAL ROOM CO₂ AND/OR AIR QUALITY SENSOR WITH AN ACTIVE OUTPUT

The RCO2-T determines the CO₂ content and the temperature of the indoor air. The CO₂ content of the air is determined by means of an NDIR sensor. Within a cycle of approx. 7 days, self-calibration of the CO₂ measurement is carried out. To ensure that this function is working properly, the unit must be supplied with fresh air (CO₂ content approx. 350 ppm) at least once within 7 days.



SENSOR MOUNTING KIT

For fastening and installing sensors with a diameter of 3.5 to 8 mm. The kit is designed for use in round pipes and drains indoors.



Operation



The control engineering offers the possibility of carrying out scalable expansions on a low-cost to a high-end basis. Further options are provided by the connection to an external building management system via Modbus RTU and the use of sensors for monitoring the indoor air quality. The settings on the ventilation unit are carried out by means of a control unit that is supplied. The unit is operated easily and intuitively via the MINI, TOUCH, PI-HMI-35T control unit and, when connected to the Internet (LAN connection), via the Pichler app. A connection of the unit to a building automation system is established using the integrated Modbus RTU interface. A gateway for the KNX bus system is also optionally available.



MINI CONTROL UNIT

The MINI control unit is used to operate the ventilation unit. It is easy to operate and enables the configuration of ventilation levels, switching between summer and winter mode, setting of basic volume flow, etc. In addition, the control unit displays the operating status, need for filter change and any errors. The standard equipment includes the USB interface in the control unit. It is installed in a flush-mounted box or on the ventilation unit (on the mounting bracket).



TOUCH CONTROL UNIT

The control unit with 4.3" colour touch display is used to operate the ventilation unit. Operation is easy and intuitive. The most important settings and readings are very easy to make. The user-friendly handling provides for automatic or manual setting of the ventilation levels. In automatic mode, the system is controlled by programmable timers, humidity or CO₂ controllers and will operate fully automatically.



PI-HMI-35T CONTROL UNIT IN CONNECTION WITH THE PICHLER AIR2 CONTROL

All the ventilation unit settings are made via the external PI-HMI control unit. The 3.5" colour touch display shows the current operating parameters and system values like for example the operating mode, fan stage, temperatures, etc. Automatic and manual mode are offered for selection.

In automatic mode, the system is controlled by programmable timers and will operate fully automatically, whilst ventilation levels may, for instance, be individually increased in manual mode (boost ventilation).

- External 3.5" colour touch display
- Version for surface mounting or flush mounting
- Dimensions: W x H x D = 80 x 121 x 42 mm



Components and accessories



CANVAS CONNECTION

Made of coated and highly tear-proof fabric and with a galvanized steel sheet flange on both sides.

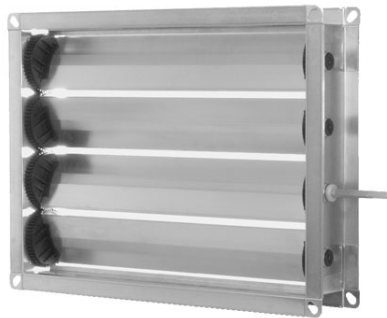

BUTTERFLY VALVE WITH WEATHERPROOF HOUSING

Galvanized frame and discs, with mounted LF 24 motor.

BUTTERFLY VALVE FOR INDOOR INSTALLATION UNITS

Galvanized frame and discs, with mounted LM 24 A motor.

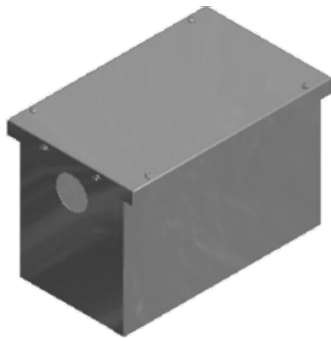

INSULATED CONDENSATE SIPHON BOX

Box of galvanized steel sheet, including mounting material, insulation wool, pipeline connections and cable inlet for the accessory pipeline heating tape. For additional insulation of the condensate drain for outdoor installation ventilation units. The siphon and the accessory pipeline heating tape are included in the scope of supply of the ventilation unit.

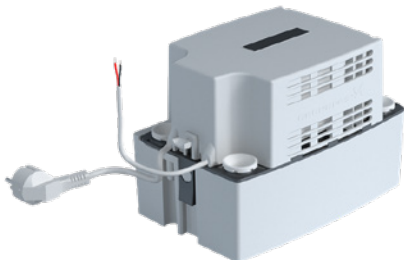

CONDENSATE LIFTING UNIT

Condensate feed pump for condensate that is collected below the sewer or that cannot enter the sewer system or the drain of the building via a natural slope. The lifting unit is ready to plug in and consists of a collection tank, pump with accessible hydraulics and two float switches.



**PASSIVE HOUSE CERTIFIED TO PHI CRITERIA**

by the Passive House Institute in Darmstadt

**ERP 2018**

Fulfils the requirements of the Ecodesign Directive, in accordance with EU Regulation 1253/2014.

**EPREL AS TO REGULATION (EU) NO. 1369/2017**

Our compact ventilation units are listed in the EPREL – European product database for energy consumption labelling.

**OUR VENTILATION UNITS**

comply with the hygienic requirements of VDI 6022

**PICHLER IS OFFICIAL MEMBER**

of the German AHU manufacturers' association
"Raumlufotechnische Geräte e.V."



Type	Design		Area of application				Heat exchanger		Ventilation of schools		Installation type				Place of installation		
	Compact	Modular design	Hygiene certified*(HY)	EPREL*	ErP*	PHI	Standard (T)	Enthalpy (F)	Decentralized school ventilation	Centralized school ventilation	Floor-mounted	Ceiling	Wall (surface mounting)	Wall (flush mounting)	Internal	Weatherproof	Integrated in the roof
LG 100	✓	-		✓	✓		-	✓	-	-	-	✓	✓	✓	✓	-	-
LG 150 A	✓	-		✓	✓	✓	✓	✓	-	-	-	✓	✓	-	✓	-	-
LG 150 B	✓	-		✓	✓		✓	✓	-	-	-	✓	✓	-	✓	-	-
LG 350	✓	-		✓	✓	✓	✓	✓	-	-	✓	-	✓	-	✓	-	-
LG 450	✓	-		✓	✓	✓	✓	✓	-	-	✓	-	✓	-	✓	-	-
LG 740	✓	-	✓	✓	✓		✓	✓	✓	-	✓	-	-	-	✓	-	-
LG 740 SK	✓	-	✓	✓	✓		-	✓	✓	-	✓	-	-	-	✓	-	-
LG 750 K	✓	✓	✓		✓	✓	✓	✓	-	-	✓	-	-	-	-	✓	✓
LG 750	-	✓	✓		✓	✓	✓	✓	-	-	✓	-	-	-	✓	✓	✓
LG 900 KNDE	✓	-	✓		✓		✓	✓	-	-		✓	-	-	✓	-	-
LG 1000 K	✓	✓	✓		✓	✓	✓	✓	-	-	✓	-	-	-	-	✓	✓
LG 1000 KN	✓	-	✓		✓		✓	✓	-	-	✓	-	-	-	-	✓	✓
LG 1000	-	✓	✓		✓	✓	✓	✓	-	-	✓	-	-	-	✓	✓	✓
LG 1000 SKDE	✓	✓	✓		✓		-	✓	✓	-		✓	-	-	✓	-	-
LG 1000 SKS	-	✓	✓		✓		-	✓	✓	-	✓	-	-	-	✓	-	-
LG 1400	✓	-	✓		✓	✓	✓	✓	-	✓	✓	-	-	-	✓	-	-
LG 1800 K	✓	✓	✓		✓		✓	✓	-	-	✓	-	-	-	-	✓	✓
LG 1800 KN	✓	-	✓		✓		✓	✓	-	-	✓	-	-	-	-	✓	✓
LG 1800	-	✓	✓		✓		✓	✓	-	-	✓	-	-	-	✓	✓	✓
LG 2500 N	-	✓	✓		✓		✓	✓	-	-	✓	-	-	-	-	✓	✓
LG 2500	-	✓	✓		✓	✓	✓	✓	-	-	✓	-	-	-	✓	✓	✓
LG 3200	✓	-	✓		✓	✓	✓	✓	-	✓	✓	-	-	-	✓	-	-
LG 4000	-	✓	✓		✓	✓	✓	✓	-	✓	✓	-	-	-	✓	✓	✓
LG 6000	-	✓	✓		✓	✓	✓	-	-	✓	✓	-	-	-	✓	✓	✓

*EPREL: EPREL as to Regulation (EU) No. 1369/2017

*ErP: ErP 2018 as to Ecodesign Directive in accordance with EU Regulation 1253/2014

*PHI: Certified passive house component

	Max. ErP limit	Core of enclosure	Without condensation discharge	Components						Operation				Control type
				EPreHB	WPreHB	EPostHB	WPostHB	WCB	Silencers	APP	MINI	TOUCH	PI-HMI-35T	
	80 m³/h	EPP	✓	●	-	-	-	-	○	✓	✓	-	-	-
	150 m³/h	EPP	-	●	○	○	○	-	○	✓	✓	✓	-	-
	200 m³/h	EPP	-	●	○	○	○	-	○	✓	✓	✓	-	-
	350 m³/h	EPP	-	●	○	○	○	○	○	✓	✓	✓	-	●
	450 m³/h	EPP	-	●	○	○	○	○	○	✓	✓	✓	-	●
	750 m³/h	Galv. sheet steel	-	●	○	○	○	○	○	✓	✓	✓	-	●
	750 m³/h	Galv. sheet steel	-	✓	○	○	○	○	○	✓	-	✓	-	●
	1000 m³/h	Galv. sheet steel	-	●	●	●	●	●	●	-	-	-	✓	●
	1000 m³/h	Galv. sheet steel	-	●	●	●	●	●	●	-	-	-	✓	●
	900 m³/h	Galv. sheet steel	-	●	●	●	●	●	●	-	-	-	✓	●
	1500 m³/h	Galv. sheet steel	-	●	●	●	●	●	●	-	-	-	✓	●
	1600 m³/h	Galv. sheet steel	-	●	●	●	●	●	○	-	-	-	✓	●
	1500 m³/h	Galv. sheet steel	-	●	●	●	●	●	●	-	-	-	✓	●
	1000 m³/h	Galv. sheet steel	✓	✓	-	○	○	○	●	✓	-	○	-	●
	1000 m³/h	Galv. sheet steel	✓	✓	-	✓	-	-	✓	✓	-	○	-	-
	1200 m³/h	Galv. sheet steel	-	○	○	○	○	○	○	-	-	-	✓	●
	2200 m³/h	Galv. sheet steel	-	●	●	●	●	●	●	-	-	-	✓	●
	2200 m³/h	Galv. sheet steel	-	●	●	●	●	●	○	-	-	-	✓	●
	2200 m³/h	Galv. sheet steel	-	●	●	●	●	●	●	-	-	-	✓	●
	3600 m³/h	Galv. sheet steel	-	●	●	●	●	●	○	-	-	-	✓	●
	2300 m³/h	Galv. sheet steel	-	●	●	●	●	●	●	-	-	-	✓	●
	3200 m³/h	Galv. sheet steel	-	○	○	○	○	○	○	-	-	-	✓	●
	4500 m³/h	Galv. sheet steel	-	●	●	●	●	●	●	-	-	-	✓	●
	7100 m³/h	Galv. sheet steel	-	●	●	●	●	●	●	-	-	-	✓	●

✓ Standard internal
 ○ Optionally external
 ● Optionally internal

PICHLER STANDARD UNIT SERIES (for new-builds and renovations)

COMPACT VENTILATION UNITS LG 100 TO LG 3200	MODULAR VENTILATION UNITS LG 750 TO LG 6000	DECENTRALIZED SCHOOL VENTILATION UNITS LG 740 TO LG 1000 SKDE
INDOOR INSTALLATION	INDOOR INSTALLATION	INDOOR INSTALLATION
WEATHERPROOF	WEATHERPROOF	
INTEGRATED IN THE ROOF	INTEGRATED IN THE ROOF	

ErP application area compact ventilation units (up to 750 m³/h)

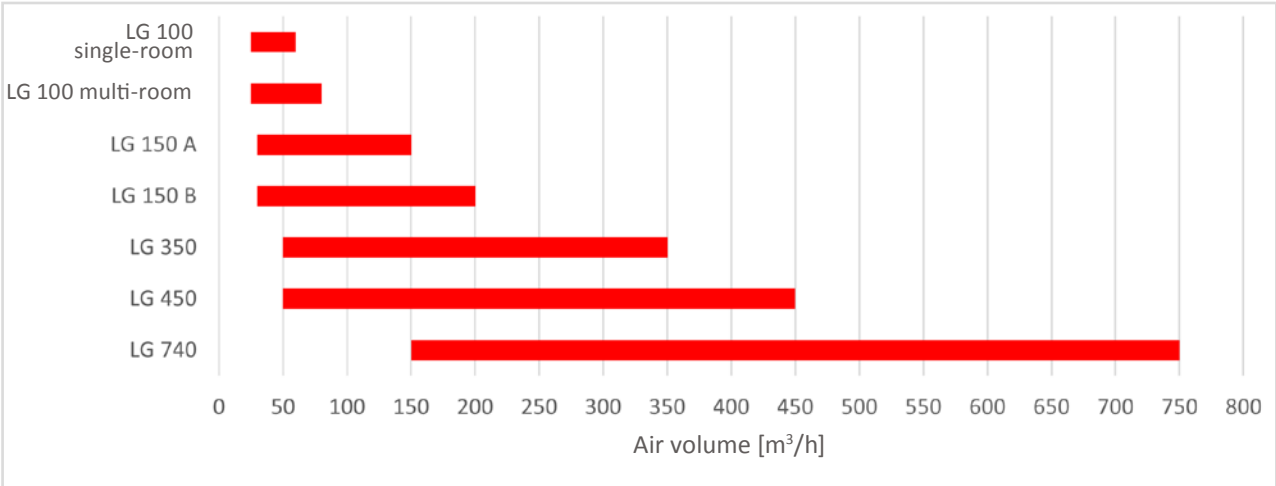

ErP application area compact ventilation units (up to 3200 m³/h)

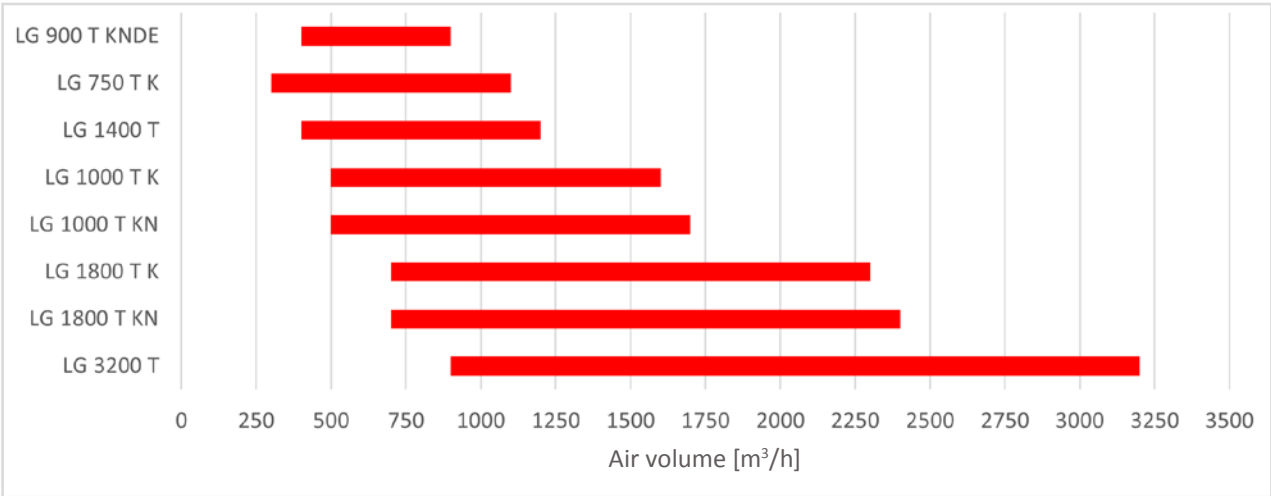

ErP application area modular ventilation units (up to 7800 m³/h)

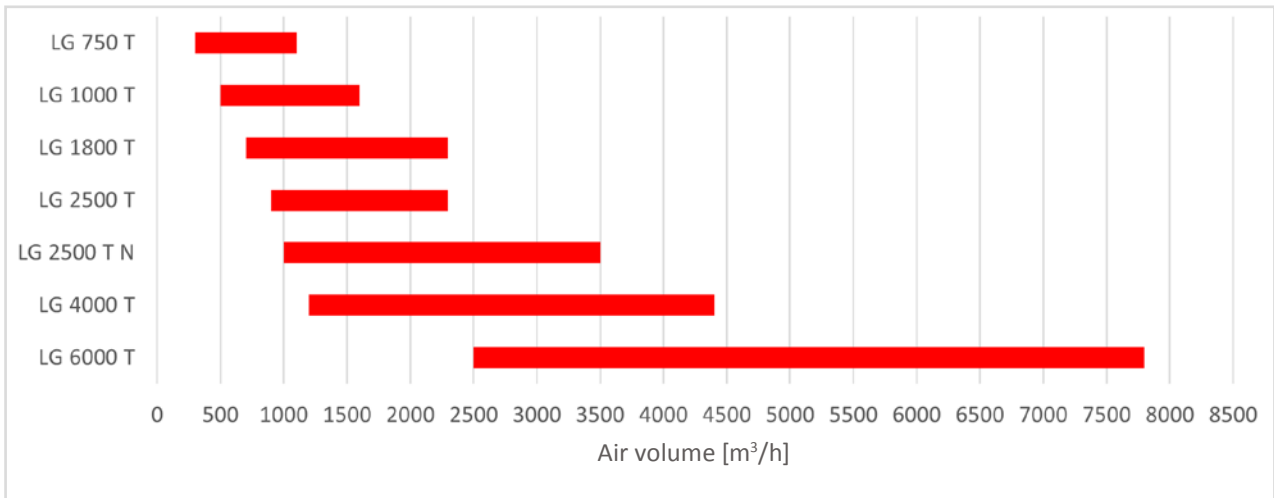

ErP application area decentralized school ventilation units (up to 1000 m³/h)

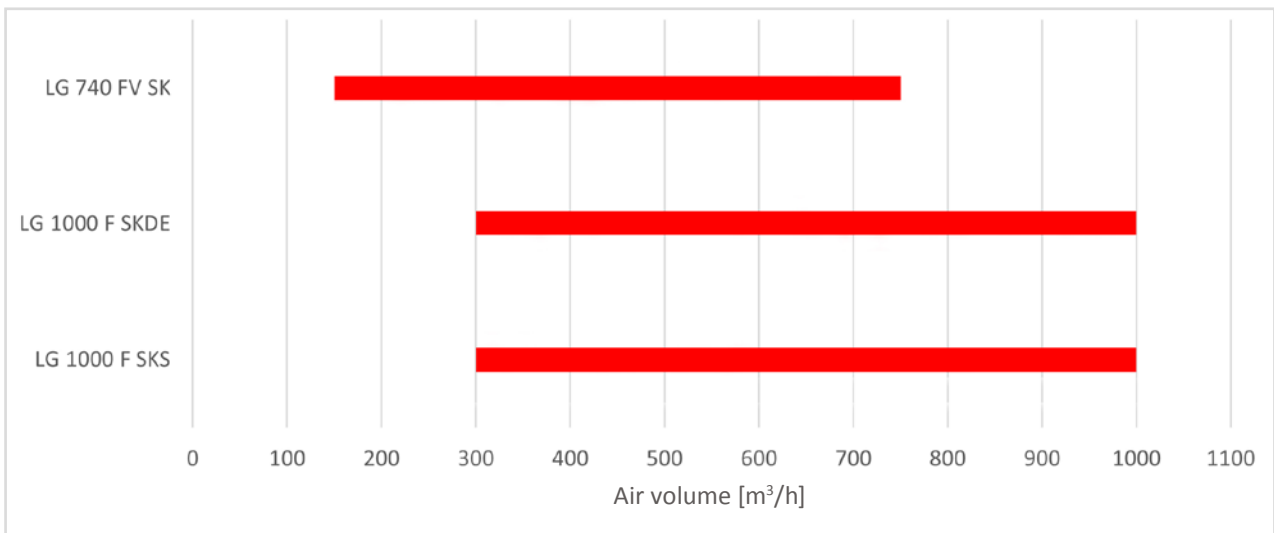

Overview of unit designations

ARTICLE NUMBER KEY LG 100

UNIT DESIGNATION: 08LG100DEFVLGLA

ARTICLE NUMBER: 08LG100DE F V L GLA

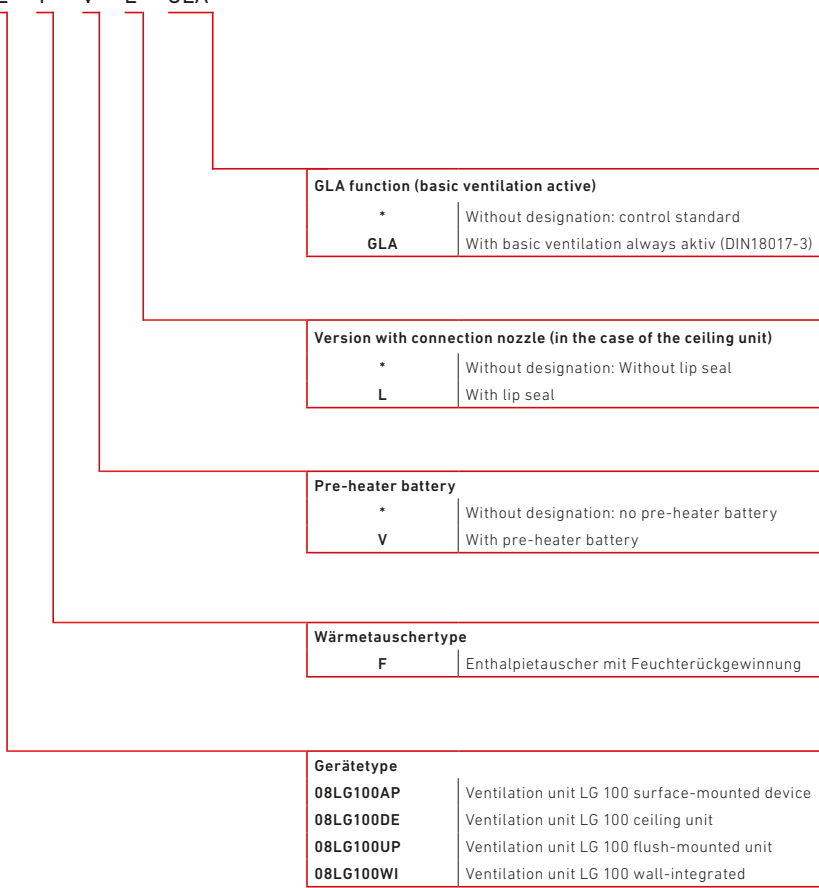

Overview of unit designations

ARTICLE NUMBER KEY LG 150 / LG 350 / LG 450 / LG 740

UNIT DESIGNATION: 08LG150ADLFFVGLA

ARTICLE NUMBER: 08LG150A D L F V GLA

Additional options	
*	Without designation: control standard
TOUCH	Unit with operating control unit TOUCH
SK	Unit for classrooms
GLA	With basic ventilation always aktiv (DIN18017-3)

Pre-heater battery	
*	Without designation: no pre-heater battery
V	With pre-heater battery

Heat exchanger type	
*	Standard heat exchanger
F	Enthalpy exchanger with humidity recovery

Version	
L	Left-hand version
R	Right-hand version

Installation site	
*	Without designation: Floor unit
D	Ceiling installation (only for LG 150)
W	Ceiling installation (only for LG 150)

Unit type	
08LG150A	Ventilation unit LG 150 A
08LG150B	Ventilation unit LG 150 B
08LG350	Ventilation unit LG 350
08LG450	Ventilation unit LG 450
08LG740	Ventilation unit LG 740



Overview of unit designations

ARTICLE NUMBER KEY LG 1400 / LG 3200

UNIT DESIGNATION: 08LG1400TSLVN

ARTICLE NUMBER: 08LG1400 T S L VN

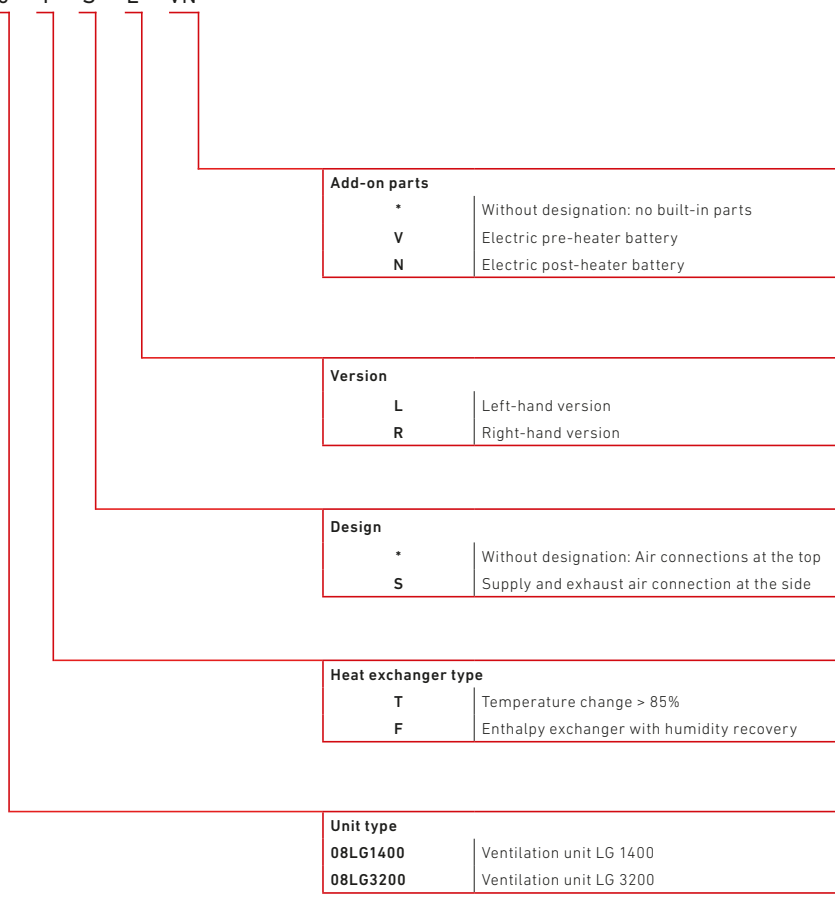

Add-on parts	
*	Without designation: no built-in parts
V	Electric pre-heater battery
N	Electric post-heater battery

Version	
L	Left-hand version
R	Right-hand version

Design	
*	Without designation: Air connections at the top
S	Supply and exhaust air connection at the side

Heat exchanger type	
T	Temperature change > 85%
F	Enthalpy exchanger with humidity recovery

Unit type	
08LG1400	Ventilation unit LG 1400
08LG3200	Ventilation unit LG 3200



Overview of unit designations

ARTICLE NUMBER KEY LG 750 TO LG 6000

UNIT DESIGNATION: LG1000 _ HY _ T _ K _ DINT _ L _ V _ VENE → LG1000_HY_T_K_DINT_L_V_VENE

ARTICLE NUMBER: 0810 HY T K D L V VENE → 0810HYTKDLVENE

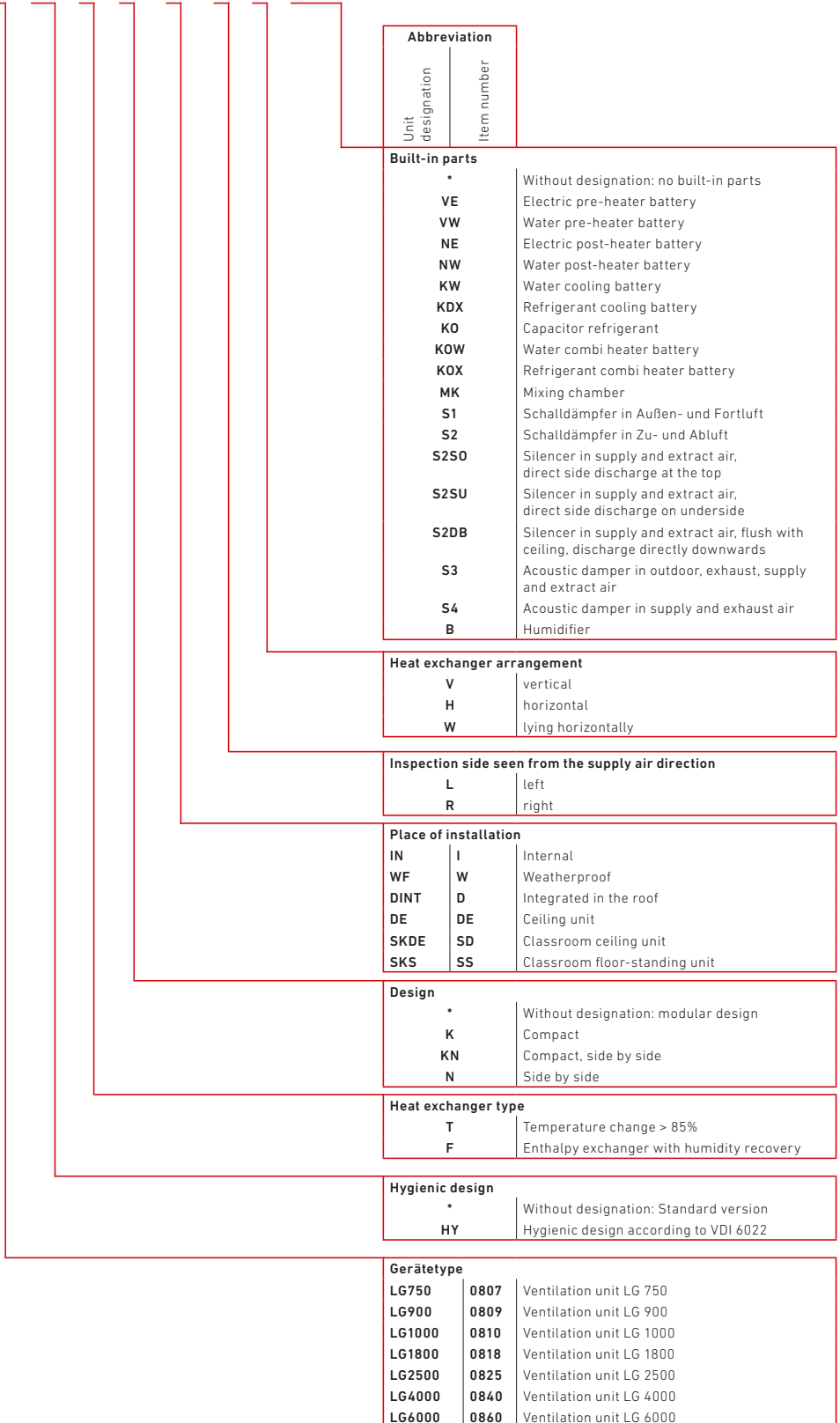

LG 100

	Single-room	Multi-room
Supply air volume [m³/h]		
V _{rated}	42	56
V _{min}	25	25
V _{max}	60	80
Dimensions (L x H x D) [mm]	Surface mounting, flush mounting: 530 x 910 x 200 Ceiling: 510 x 900 x 200	
Weight [kg]	~25	
Panel wall thickness [mm]	EPP core	
Duct connection Ø [mm]	Ø 125 sleeve (ODA/EHA) with wall duct Ø 100 nipple (ODA/EHA) with housing connection up to 6x KomFlex 75 (SUP/ETA) with multi-room connection	
Fan type	EC	
Maximum power consumption [W]	40 (without heater battery)	
Heat exchanger type	Enthalpy counterflow heat exchanger	
Moisture transfer rate [%]	69.1	64.3
Thermal transfer rate dry [%]	83.6	80,4
Specific fan power, validation SFPv [Wh/m³]	0.28	0.32
Power consumption, validation [W]	12	18
Standard filter classes (outdoor air/extract air)	Coarse 70% + ePM1 55% / Coarse 70%	



DESIGN DRAWING

Surface-mounted unit

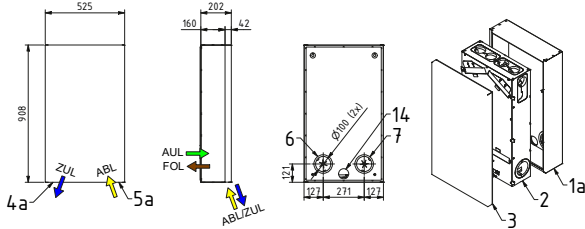

Insert block

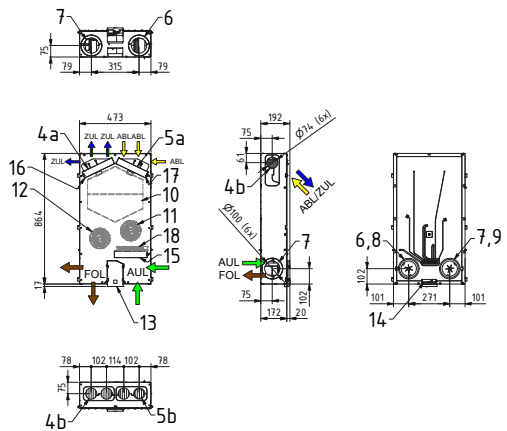

Ceiling unit

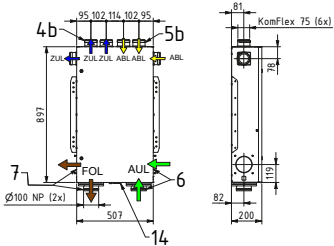

Flush-mounted unit

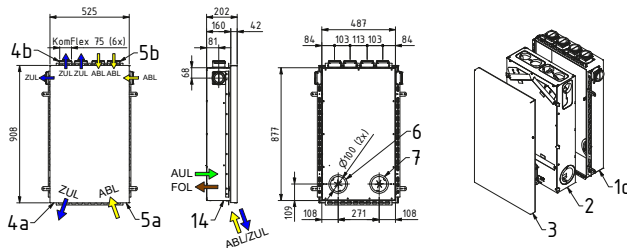

- 1a Surface-mounted housing
- 1b Ceiling housing
- 1c Flush-mounted housing
- 2 Insert block
- 3 Design front
- 4a Supply air blowing out freely (slide controller)
- 4b Supply air connection
- 5a Extract air, with free intake (slide controller)
- 5b Extract air connection
- 6 Outdoor air connection
- 7 Exhaust air connection
- 8 Butterfly valve outdoor air with servo drive
- 9 Butterfly valve exhaust air with servo drive
- 10 Enthalpy counterflow heat exchanger
- 11 Supply air fan
- 12 Exhaust air fan
- 13 Controller
- 14 Cable entries
- 15 Outdoor air filter
- 16 Supply air filter
- 17 Extract air filter
- 18 Pre-heater battery



LG 150

	A version		B version	
Supply air volume [m³/h]				
<i>V_{rated}</i>	105		125	
<i>V_{min}</i>	30		30	
<i>V_{max}</i>	150		200	
Dimensions (L x H x D) [mm]	680 x 780 x 290			
Weight [kg]	~30			
Panel wall thickness [mm]	EPP core			
Duct connection Ø [mm]	Ø 125 nipple SAFE			
Fan type	EC			
Maximum power consumption [W]	168 (without heater battery)		232 (without heater battery)	
Heat exchanger type	Standard	Enthalpy	Standard	Enthalpy
Moisture transfer rate [%]		61.7		56.9
Thermal transfer rate dry [%]	92.4	84.2	90.9	83.4
Specific fan power, validation SFPv [Wh/m³]	0.25	0.24	0.41	0.36
Power consumption, validation [W]	26	25	51	45
Standard filter classes (outdoor air/extract air)	ePM2.5 55% / coarse 70%			



DESIGN DRAWING (RIGHT-HAND VERSION)

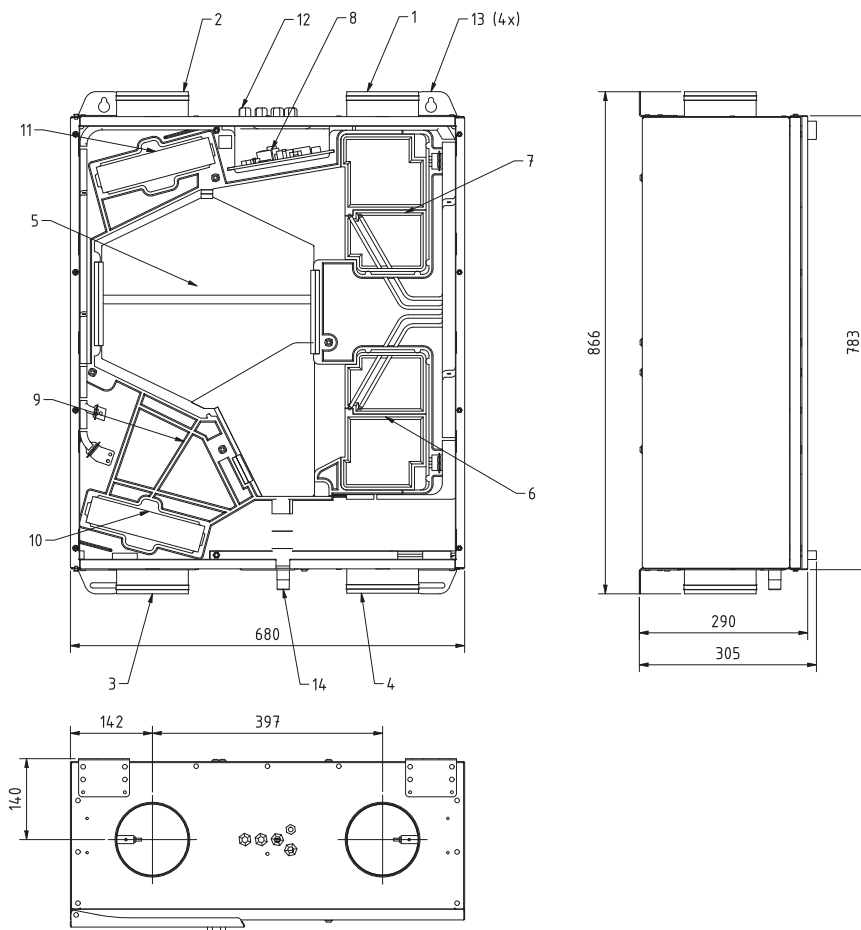

- 1 Supply air Ø 125 mm
- 2 Extract air Ø 125 mm
- 3 Outdoor air Ø 125 mm
- 4 Exhaust air Ø 125 mm
- 5 Counterflow heat exchanger with condensate tray
- 6 Exhaust air fan
- 7 Supply air fan
- 8 Controller
- 9 Bypass flap with pre-heater battery (optional)
- 10 ODA filter ISO ePM2.5 55%
- 11 ETA filter ISO coarse 70%
- 12 Cable inlet
- 13 Assembly bracket
- 14 Condensate outlet R1/2" outside thread



LG 350 & LG 450

	LG 350		LG 450	
Supply air volume [m³/h]				
V_{rated}	245		315	
V_{min}	50		50	
V_{max}	350		450	
Dimensions (L x H x D) [mm]	830 x 910 x 570			
Weight [kg]	~56			
Panel wall thickness [mm]	EPP core			
Duct connection Ø [mm]	Ø 160 sleeve			
Fan type	EC			
Maximum power consumption [W]	180 (without heater battery)		350 (without heater battery)	
Heat exchanger type	Standard	Enthalpy	Standard	Enthalpy
Moisture transfer rate [%]		69.2		64.5
Thermal transfer rate dry [%]	93	81	91	79
Specific fan power, validation SFPv [Wh/m³]	0.19	0.17	0.24	0.21
Power consumption, validation [W]	47	42	76	66
Standard filter classes (outdoor air/extract air)	ePM1 60% / coarse 80%			



DESIGN DRAWING (RIGHT-HAND VERSION)

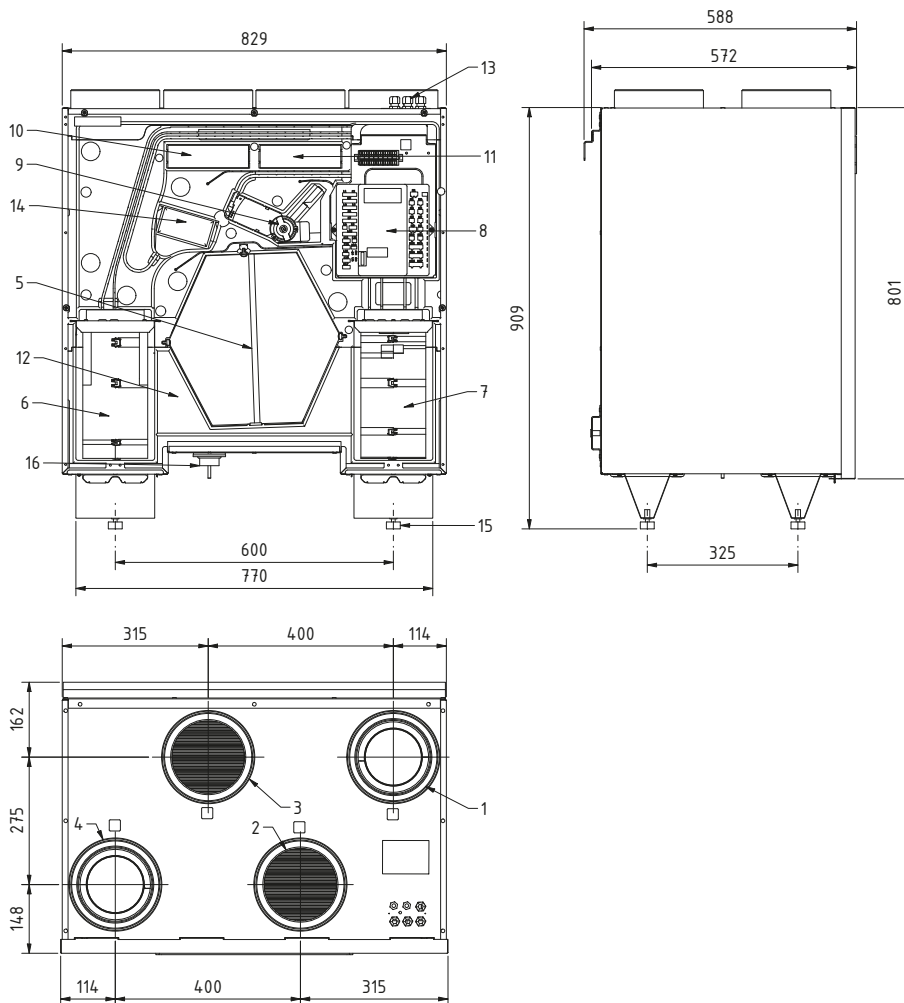

- 1 Supply air DN160
- 2 Extract air DN160
- 3 Outdoor air DN160
- 4 Exhaust air DN160
- 5 Counterflow heat exchanger
- 6 Exhaust air fan
- 7 Supply air fan
- 8 Controller
- 9 Bypass flap
- 10 ODA filter ISO ePM1 60%
- 11 ETA filter ISO Coarse 80%
- 12 Condensate tray
- 13 Cable inlets
- 14 Electric pre-heater battery (optional)
- 15 Height-adjustable feet (console removable)
- 16 Condensate outlet DN40



LG 740

	Standard	Enthalpy
Supply air volume [m³/h]		
V _{rated}	525	525
V _{min}	150	150
V _{max}	750	750
Dimensions (L x H x D) [mm]	1090 x 940 x 660	
Weight [kg]	~120	
Panel wall thickness [mm]	25	
Duct connection Ø [mm]	Ø 200 nipple SAFE	
Fan type	EC	
Maximum power consumption [W]	400 (without heater battery)	
Heat exchanger type	Counterflow heat exchanger	Enthalpy counterflow heat exchanger
Moisture transfer rate [%]		70
Thermal transfer rate dry [%]	85.5	80.5
Specific fan power, validation SFPv [Wh/m³]	0.2	0.2
Power consumption, validation [W]	105	105
Standard filter classes (outdoor air/extract air)	ePM1 55% / coarse 70%	



DESIGN DRAWING (RIGHT-HAND VERSION)

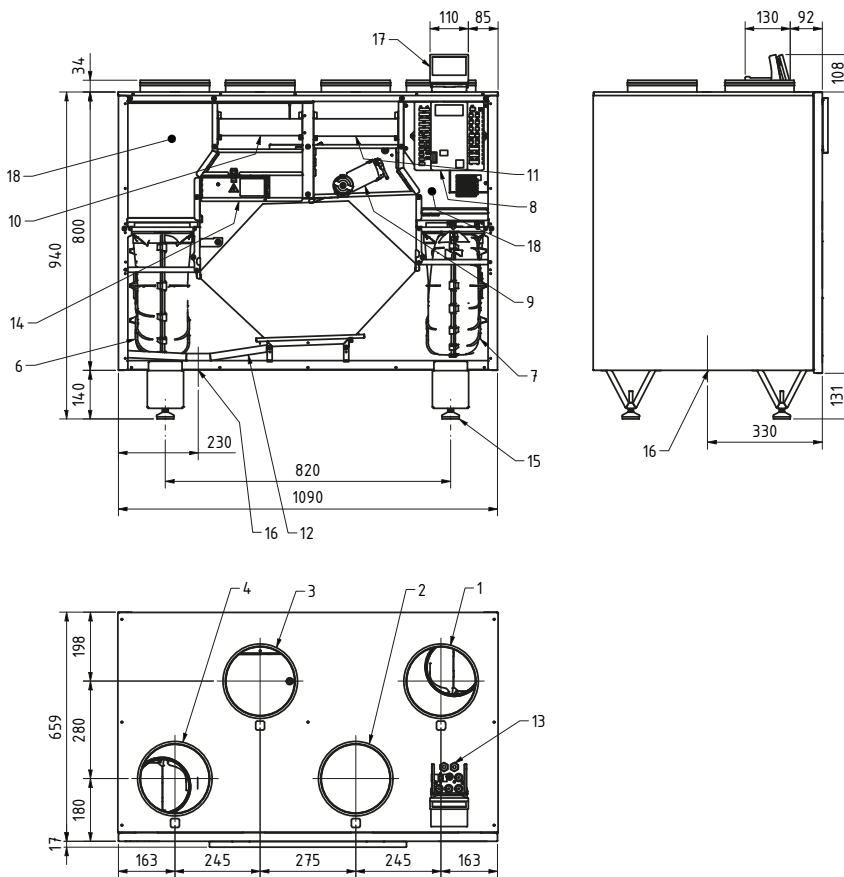

- 1 Supply air DN200
- 2 Extract air DN200
- 3 Outdoor air DN200
- 4 Exhaust air DN200
- 5 Counterflow heat exchanger (optionally with moisture recovery)
- 6 Exhaust air fan
- 7 Supply air fan
- 8 Controller
- 9 Bypass flap drive
- 10 ODA filter ISO ePM1 55%
- 11 ETA filter ISO Coarse 70%
- 12 Condensate tray
- 13 Cable inlets
- 14 Electric pre-heater battery (optional)
- 15 Height-adjustable feet
- 16 Condensate outlet 1 1/4" outside thread
- 17 Mounting bracket for the MINI or TOUCH control unit
- 18 Integrated acoustic dampers (supply and exhaust air)



LG 750 K WF/DINT

	T version	F version
Supply air volume [m³/h]		
V_{rated}	700	700
V_{min}	300	400
V_{max}	1100	1100
Dimensions (L x H x D) [mm]	2150 x 1260 x 810	
Weight [kg]	~530	
Panel wall thickness [mm]	100	
Duct connection (w x h) [mm]	480 x 345 P30 320 x 270 for sliding type fittings (SUP/ETA in the case of units integrated into the roof)	
Fan type	EC	
Maximum power consumption [W]	1200 (without heater battery)	
Heat exchanger type	Counterflow heat exchanger	Enthalpy counterflow heat exchanger
Moisture transfer rate [%]		69.4
Thermal transfer rate dry [%]	85.5	78.1
Specific fan power, validation SFPv [Wh/m³]	0.37	0.39
Power consumption, validation [W]	259	273
Standard filter classes (outdoor air/extract air)	ePM1 55% / ePM10 75%	

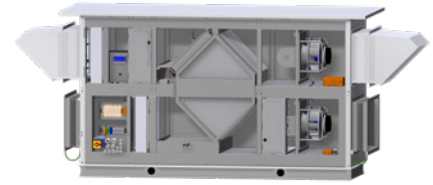

DESIGN DRAWING (RIGHT-HAND VERSION)

Caution: Drawing not true to scale. See underlined dimensions.

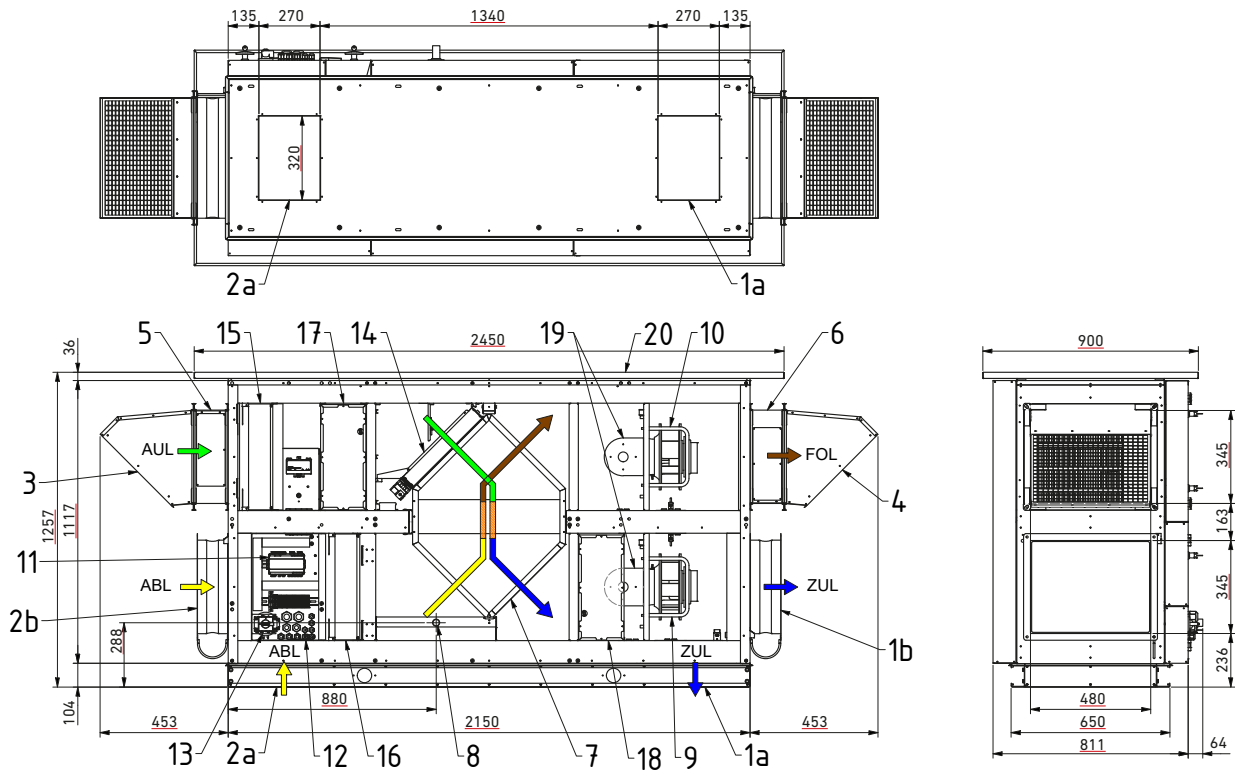

1a Supply air connection for versions with integration into the roof, for sliding type fittings

1b Supply air connection weather-proof version with canvas connection

2a Extract air connection for versions with integration into the roof, for sliding type fittings

2b Extract air connection weather-proof version with canvas connection

3 Outdoor air connection with hood

4 Exhaust air connection with hood

5 Butterfly valve outdoor air with servo drive

6 Butterfly valve exhaust air with servo drive

7 Counterflow heat exchanger with bypass (optional enthalpy)

8 Condensate tray heat exchanger with condensate drain Ø 32 mm

9 Supply air fan

10 Exhaust air fan

11 Controller

12 Cable entries

13 Main switch

14 Bypass flap with servo motor

15 Outdoor air filter

16 Extract air filter

17 Pre-heater battery

18 Post-heater battery

19 Duct smoke detector

20 Unit roof



LG 900 KN DE

	T version	F version
Supply air volume [m³/h]		
V _{rated}	600	600
V _{min}	400	400
V _{max}	900	900
Dimensions (L x H x D) [mm]	2220 x 490 x 1290	
Weight [kg]	~300	
Panel wall thickness [mm]	30	
Duct connection (w x h) [mm]	440 x 306 P20	
Fan type	EC	
Maximum power consumption [W]	1720 (without heater battery)	
Heat exchanger type	Counterflow heat exchanger	Enthalpy counterflow heat exchanger
Moisture transfer rate [%]		72.3
Thermal transfer rate dry [%]	85.2	80.5
Specific fan power, validation SFPv [Wh/m³]	0.4	0.38
Power consumption, validation [W]	240	228
Standard filter classes (outdoor air/extract air)	ePM1 55% / ePM10 75%	

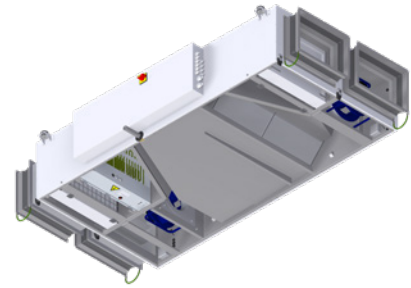

DESIGN DRAWING (RIGHT-HAND VERSION)

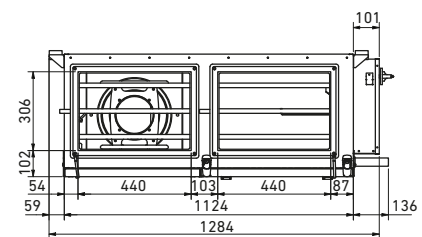
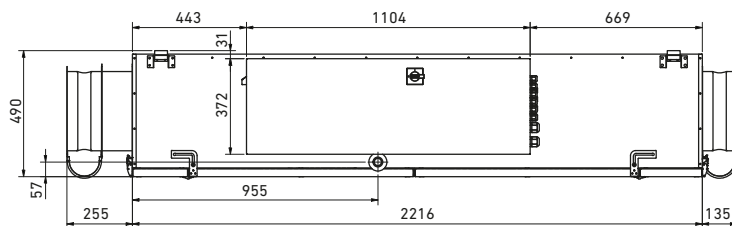
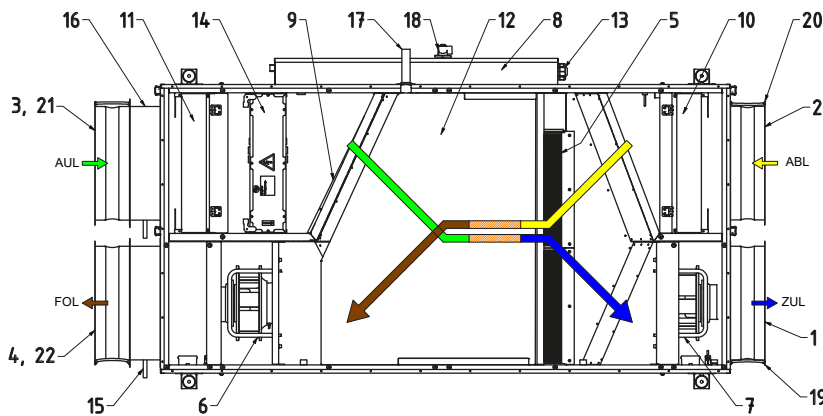

- | | | | |
|--|--------------------------------|--|---|
| 1 Supply air 440 x 306 mm | 7 Supply air fan | 14 Electric pre-heater battery | 19 Canvas connection supply air P20 (optional) |
| 2 Extract air 440 x 306 mm | 8 Controller | 15 Butterfly valve EHA with servo drive (optional) | 20 Canvas connection extract air P20 (optional) |
| 3 Outdoor air 440 x 306 mm | 9 Bypass flap with servo motor | 16 Butterfly valve ODA with servo drive (optional) | 21 Canvas connection outdoor air P20 (optional) |
| 4 Exhaust air 440 x 306 mm | 10 Extract air filter | 17 Condensate drain heat exchanger Ø 32 mm | 22 Canvas connection exhaust air P20 (optional) |
| 5 Counterflow heat exchanger with bypass (optional enthalpy) | 11 Outdoor air filter | 18 Main switch | |
| 6 Exhaust air fan | 12 Condensate tray | | |
| | 13 Cable entries | | |



LG 1000 IN

	T version	F version
Supply air volume [m³/h]		
V _{rated}	900	900
V _{min}	500	500
V _{max}	1600	1600
Dimensions (L x H x D) [mm]	2200 x 1200 x 760	
Weight [kg]	~450	
Panel wall thickness [mm]	50	
Duct connection (w x h) [mm]	530 x 410 P30	
Fan type	EC	
Maximum power consumption [W]	1200 (without heater battery)	
Heat exchanger type	Counterflow heat exchanger	Enthalpy counterflow heat exchanger
Moisture transfer rate [%]		71.9
Thermal transfer rate dry [%]	85.5	79.5
Specific fan power, validation SFPv [Wh/m³]	0.33	0.34
Power consumption, validation [W]	297	306
Standard filter classes (outdoor air/extract air)	ePM1 55% / ePM10 75%	



DESIGN DRAWING (RIGHT-HAND VERSION)

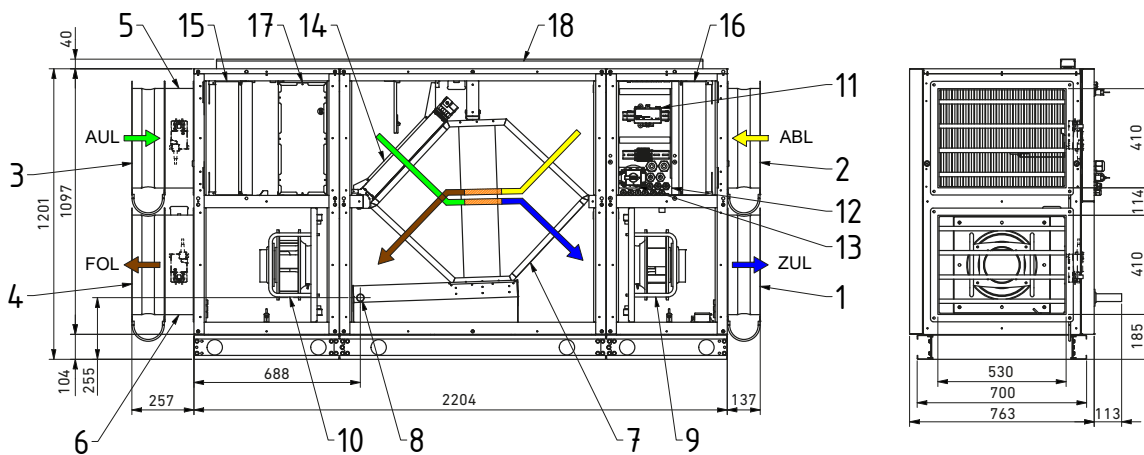

- | | | |
|---|--|---------------------------------|
| 1 Supply air connection with canvas connection | 6 Butterfly valve exhaust air with servo drive | 12 Cable entries |
| 2 Extract air connection with canvas connection | 7 Counterflow heat exchanger with bypass (optional enthalpy) | 13 Main switch |
| 3 Outdoor air connection with canvas connection | 8 Condensate tray heat exchanger with condensate drain Ø 32 mm | 14 Bypass flap with servo motor |
| 4 Exhaust air connection with canvas connection | 9 Supply air fan | 15 Outdoor air filter |
| 5 Butterfly valve outdoor air with servo drive | 10 Exhaust air fan | 16 Extract air filter |
| | 11 Controller | 17 Pre-heater battery |
| | | 18 Cable duct |



LG 1000 K WF/DINT

	T version	F version
Supply air volume [m³/h]		
V _{rated}	900	900
V _{min}	500	500
V _{max}	1600	1600
Dimensions (L x H x D) [mm]	2300 x 1390 x 860	
Weight [kg]	~600	
Panel wall thickness [mm]	100	
Duct connection (w x h) [mm]	530 x 410 P30 370 x 270 for sliding type fittings (SUPPLY AIR/EXTRACT AIR in the case of units integrated into the roof)	
Fan type	EC	
Maximum power consumption [W]	1200 (without heater battery)	
Heat exchanger type	Counterflow heat exchanger	Enthalpy counterflow heat exchanger
Moisture transfer rate [%]		71.9
Thermal transfer rate dry [%]	85.5	79.5
Specific fan power, validation SFPv [Wh/m³]	0.33	0.34
Power consumption, validation [W]	297	306
Standard filter classes (outdoor air/extract air)	ePM1 55% / ePM10 75%	

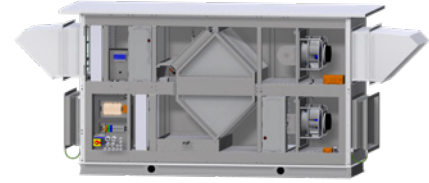

DESIGN DRAWING (RIGHT-HAND VERSION)

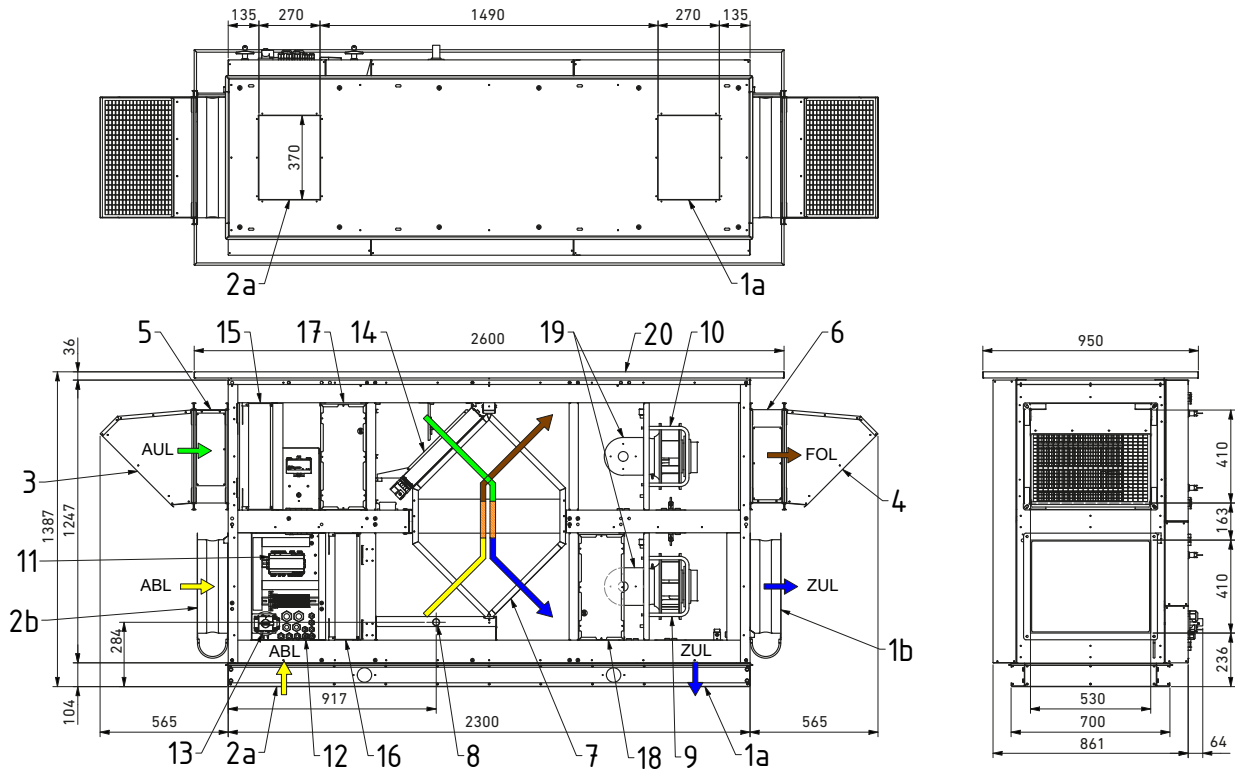

1a Supply air connection for versions with integration into the roof, for sliding type fittings

1b Supply air connection weather-proof version with canvas connection

2a Extract air connection roof-integrated version for sliding type fittings

2b Extract air connection weather-proof version with canvas connection

3 Outdoor air connection with hood

4 Exhaust air connection with hood

5 Butterfly valve outdoor air with servo drive

6 Butterfly valve exhaust air with servo drive

7 Counterflow heat exchanger with bypass (optional enthalpy)

8 Condensate tray heat exchanger with condensate drain Ø 32 mm

9 Supply air fan

10 Exhaust air fan

11 Controller

12 Cable entries

13 Main switch

14 Bypass flap with servo motor

15 Outdoor air filter

16 Extract air filter

17 Pre-heater battery

18 Post-heater battery

19 Duct smoke detector

20 Unit roof



LG 1000 KN WF/DINT

	T version	F version
Supply air volume [m³/h]		
V _{rated}	1200	1200
V _{min}	500	600
V _{max}	1700	1700
Dimensions (L x H x D) [mm]	3710 x 1080 x 1160	
Weight [kg]	~850	
Panel wall thickness [mm]	100	
Duct connection (w x h) [mm]	300 x 506 P30 (SUP/ETA with weather-proof units) 300 x 506 for sliding type fittings (SUP/ETA for units integrated into the roof) 400 x 600 P30 (ODA/EHA)	
Fan type	EC	
Maximum power consumption [W]	1200 (without heater battery)	
Heat exchanger type	Counterflow heat exchanger	Enthalpy counterflow heat exchanger
Moisture transfer rate [%]		67.7
Thermal transfer rate dry [%]	85	77
Specific fan power, validation SFPv [Wh/m³]	0.34	0.36
Power consumption, validation [W]	408	432
Standard filter classes (outdoor air/extract air)	ePM1 55% / ePM10 75%	



DESIGN DRAWING (LEFT-HAND VERSION)

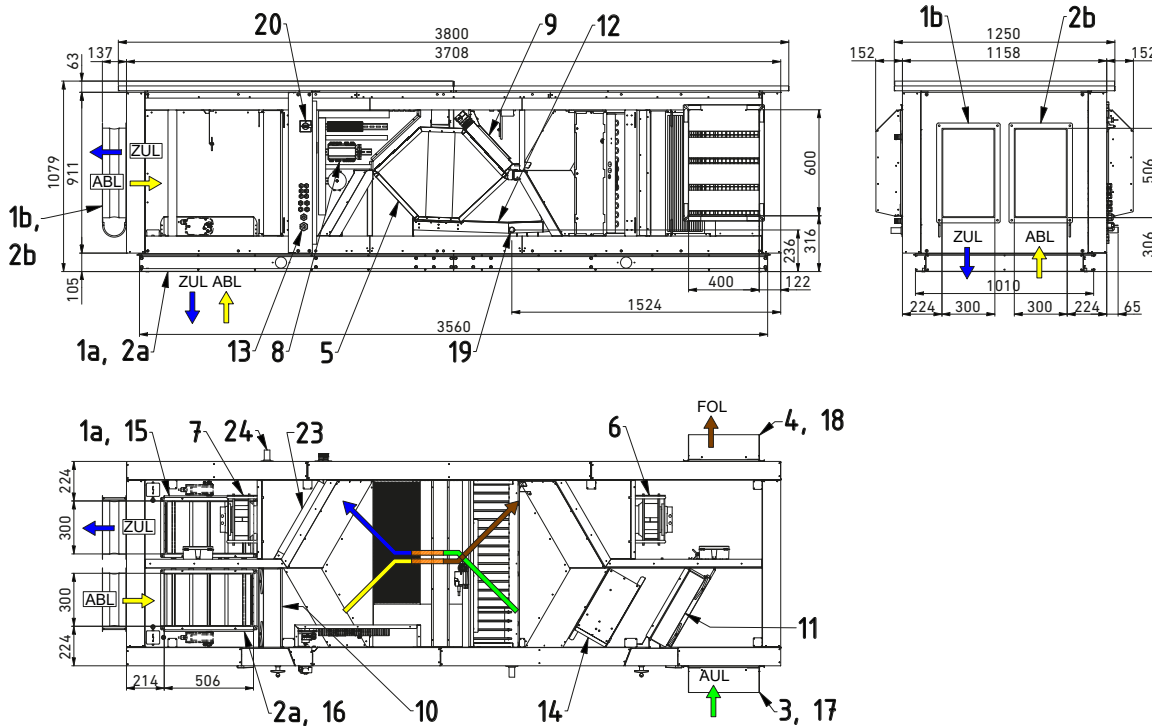

1a Supply air connection roof-integrated version for sliding type fittings

1b Supply air connection weather-proof version with canvas connection

2a Extract air connection roof-integrated version for sliding type fittings

2b Extract air connection weather-proof version with canvas connection

3 Outdoor air 400 x 600 mm

4 Exhaust air 400 x 600 mm

5 Counterflow heat exchanger with bypass (optional enthalpy)

6 Exhaust air fan

7 Supply air fan

8 Controller

9 Bypass flap with servo motor

10 Extract air filter

11 Outdoor air filter

12 Condensate tray heat exchanger

13 Cable entries 1 x M32, 1 x M25, 4 x M20, 6 x M16

14 Electric pre-heater battery

15 Butterfly valve supply air with servo drive (optional)

16 Butterfly valve extract air with servo drive (optional)

17 Outdoor air hood (with optional duct connection)

18 Exhaust air hood (with optional duct connection)

19 Condensate drain heat exchanger Ø 32 mm

20 Main switch

21 Canvas connection supply air P30 (optional)

22 Canvas connection extract air P30 (optional)

23 Combi heater water, heating, cooling (KOW, optional)

24 Condensate drain combi heater Ø 32 mm (KOW, optional)"



LG 1000 SKDE

	F version
Supply air volume [m³/h]	
V _{rated}	700
V _{min}	300
V _{max}	1000
Dimensions (L x H x D) [mm]	2010 x 479 x 1020
Weight [kg]	~200
Panel wall thickness [mm]	30
Duct connection Ø [mm]	Ø 315 sleeve
Fan type	EC
Maximum power consumption [W]	3000 (with heater battery)
Heat exchanger type	Enthalpy counterflow heat exchanger
Moisture transfer rate [%]	41
Thermal transfer rate dry [%]	76.9
Specific fan power, validation SFPv [Wh/m³]	0.26
Standard filter classes (outdoor air/extract air)	ePM1 55% / ePM10 75%

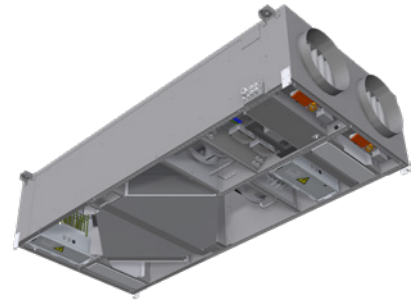

DESIGN DRAWING (RIGHT-HAND VERSION)

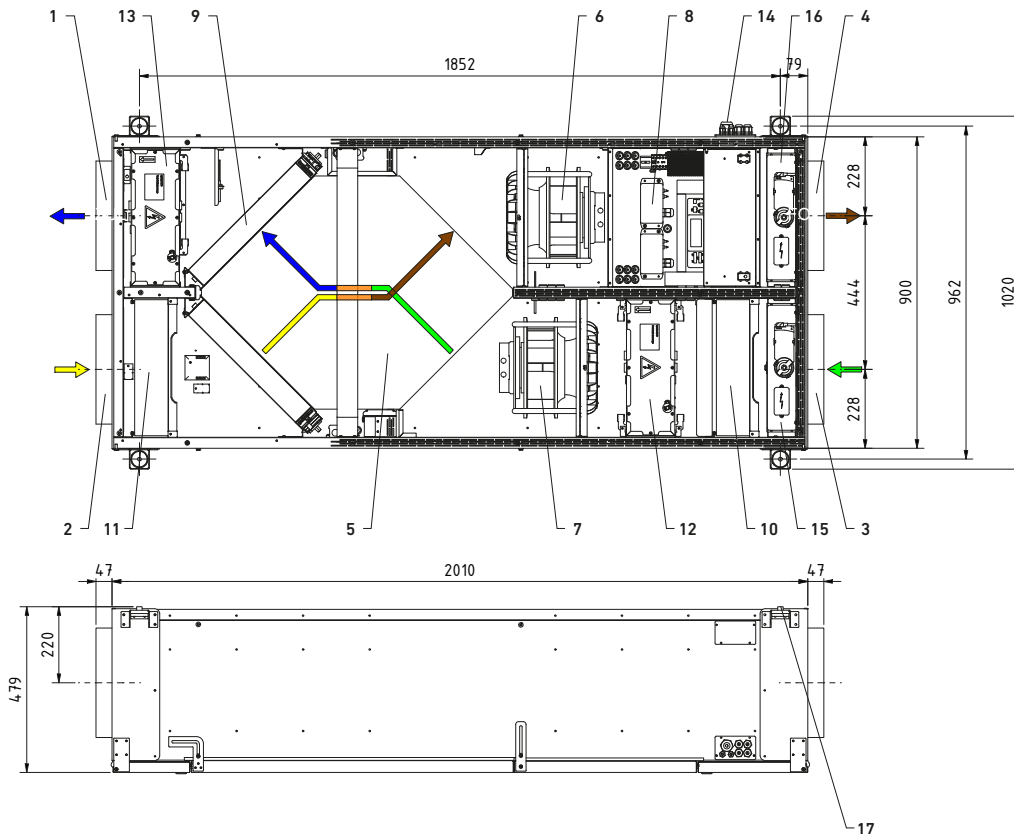

- 1 Supply air SUP Ø 315 sleeve size
- 2 Extract air ETA Ø 315 sleeve size
- 3 Outdoor air ODA Ø 315 sleeve size
- 4 Exhaust air EHA Ø 315 sleeve size
- 5 Counterflow heat exchanger (with moisture recovery)
- 6 Exhaust air EHA fan
- 7 Supply air SUP fan
- 8 Controller
- 9 Bypass flap
- 10 Outdoor air ODA filter ISO ePM1 55%
- 11 Exhaust air EHA filter ISO ePM10 75%
- 12 Electric pre-heater battery
- 13 Electric re-heater battery
- 14 Cable inlets (for device connection)
- 15 Outdoor air ODA flap
- 16 Exhaust air EHA flap
- 17 Anti-vibration mounting



LG 1000 SKS

	F version
Supply air volume [m³/h]	
V_{rated}	700
V_{min}	300
V_{max}	1000
Dimensions (L x H x D) [mm]	2010 x 2091 x 531
Weight [kg]	~390
Panel wall thickness [mm]	30
Duct connection Ø [mm]	Ø 315 sleeve (outdoor air/exhaust air)
Fan type	EC
Maximum power consumption [W]	3000 (with heater battery)
Heat exchanger type	Enthalpy counterflow heat exchanger
Moisture transfer rate [%]	42.16
Thermal transfer rate dry [%]	77.9
Specific fan power, validation SFPv [Wh/m³]	0.23
Standard filter classes (outdoor air/extract air)	ePM1 55% / ePM10 75%



DESIGN DRAWING (LEFT-HAND VERSION)

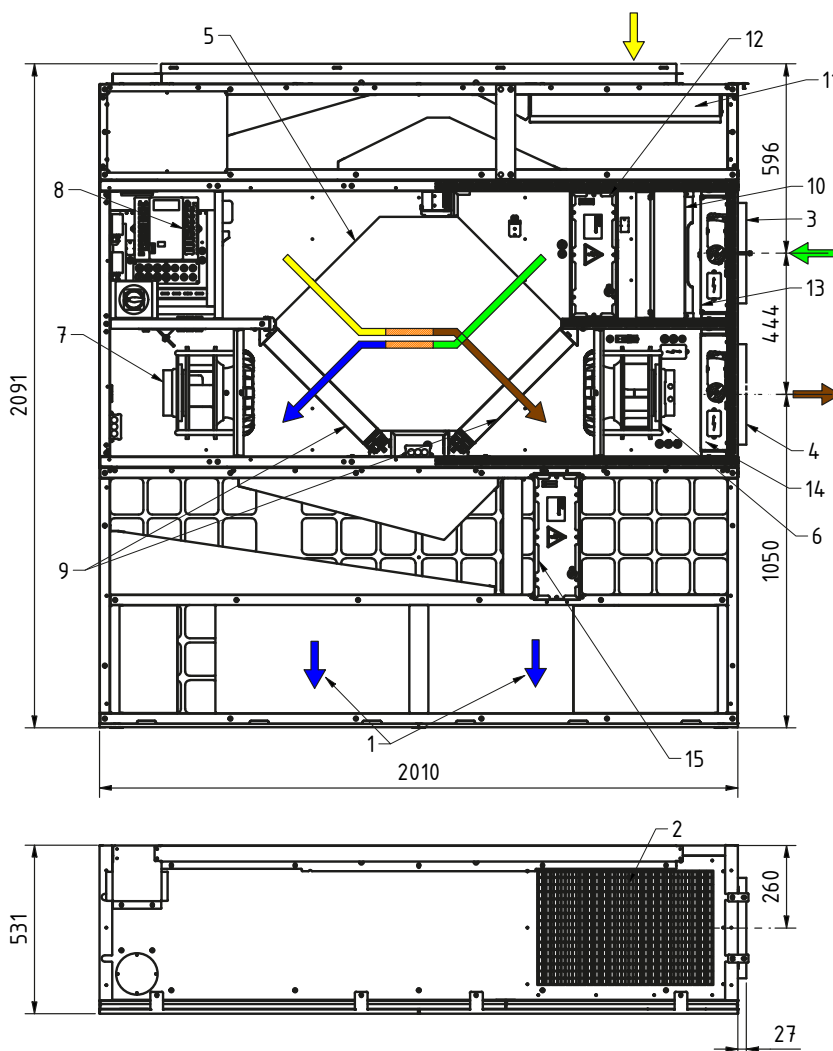

- 1 Supply air
- 2 Extract air
- 3 Outdoor air Ø 315 sleeve size
- 4 Exhaust air Ø 315 sleeve size
- 5 Counterflow heat exchanger (with moisture recovery)
- 6 Exhaust air fan
- 7 Supply air fan
- 8 Controller
- 9 Bypass flap
- 10 ODA filter ISO ePM1 55%
- 11 ETA filter ISO ePM10 75%
- 12 Electric pre-heater battery
- 13 Outdoor air flap
- 14 Exhaust air flap
- 15 Electric post-heater battery



LG 1400

	T version	F version
Supply air volume [m³/h]		
V _{rated}	800	800
V _{min}	400	400
V _{max}	1200	1200
Dimensions (L x H x D) [mm]	1440 x 1290 x 760	
Weight [kg]	~190	
Panel wall thickness [mm]	50	
Duct connection (w x h) [mm]	596 x 200 P30 286 x 586 P30 (supply air/exhaust air for units with lateral connections)	
Fan type	EC	
Maximum power consumption [W]	1200 (without heater battery)	
Heat exchanger type	Counterflow heat exchanger	Enthalpy counterflow heat exchanger
Moisture transfer rate [%]		68.9
Thermal transfer rate dry [%]	85.4	77.8
Specific fan power, validation SFPv [Wh/m³]	0.35	0.36
Power consumption, validation [W]	280	288
Standard filter classes (outdoor air/extract air)	ePM1 55% / coarse 90%	

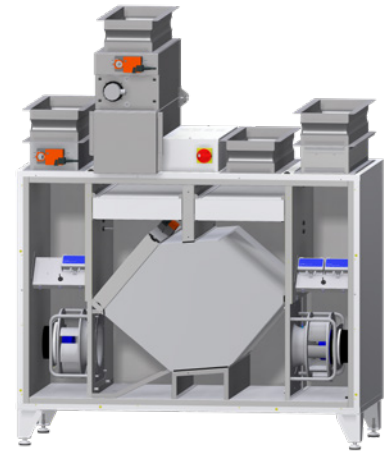

DESIGN DRAWING (RIGHT-HAND VERSION)

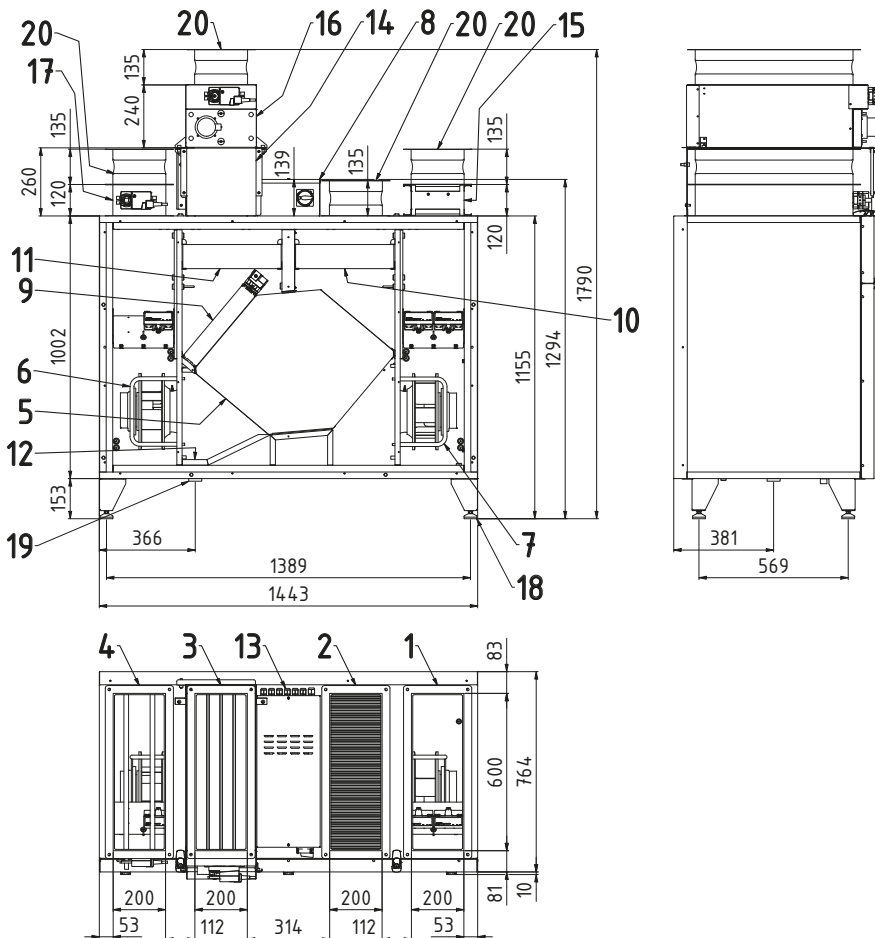

- 1 Supply air 200 x 596 mm
- 2 Extract air 200 x 596 mm
- 3 Outdoor air 200 x 596 mm
- 4 Exhaust air 200 x 596 mm
- 5 Counterflow heat exchanger
- 6 Exhaust air fan
- 7 Supply air fan
- 8 Controller
- 9 Bypass flap with servo motor
- 10 Extract air filter
- 11 Outdoor air filter
- 12 Condensate tray
- 13 Cable entries
2 x M20, 8 x M16
- 14 Electric pre-heater battery, with heat insulation (optional)
- 15 Electric post-heater battery (optional)
- 16 Filter and flap box (required in connection with electric pre-heater battery) or butterfly valve supply air (optional, without electric pre-heater battery, 120 mm height)
- 17 Butterfly valve exhaust air (optional)
- 18 Height-adjustable feet
- 19 Condensate drain
- 20 Elastic connectors on top



LG 1800 IN

	T version	F version
Supply air volume [m³/h]		
V_{rated}	1500	1500
V_{min}	700	800
V_{max}	2300	2300
Dimensions (L x H x D) [mm]	2200 x 1200 x 1110	
Weight [kg]	~600	
Panel wall thickness [mm]	50	
Duct connection (w x h) [mm]	880 x 410 P30	
Fan type	EC	
Maximum power consumption [W]	1720 (without heater battery)	
Heat exchanger type	Counterflow heat exchanger	Enthalpy counterflow heat exchanger
Moisture transfer rate [%]		71.3
Thermal transfer rate dry [%]	85.2	79.3
Specific fan power, validation SFPv [Wh/m³]	0.33	0.35
Power consumption, validation [W]	495	525
Standard filter classes (outdoor air/extract air)	ePM1 55% / ePM10 75%	



DESIGN DRAWING (RIGHT-HAND VERSION)

Caution: Drawing not true to scale. See underlined dimensions.

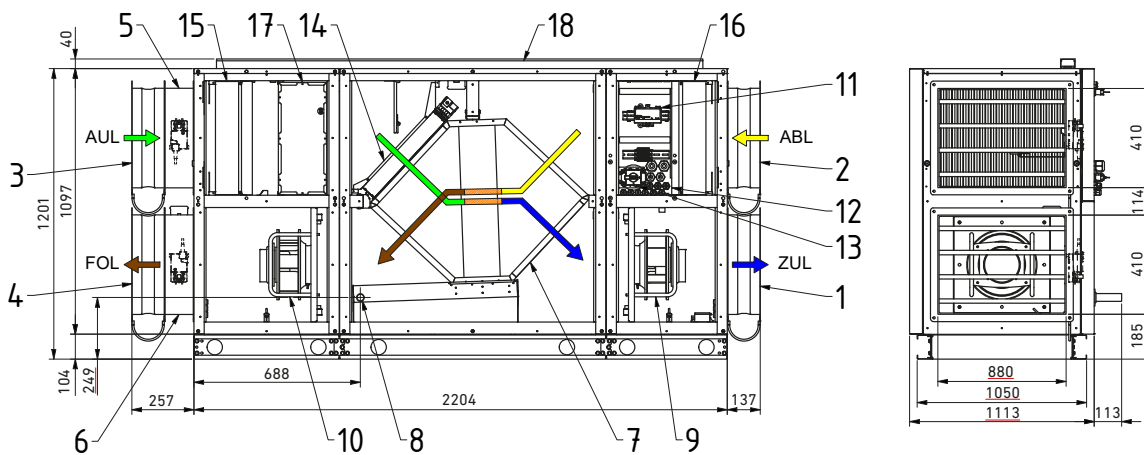

- | | | | |
|---|---|---|---|
| <ul style="list-style-type: none"> 1 Supply air connection with canvas connection 2 Extract air connection with canvas connection 3 Outdoor air connection with canvas connection 4 Exhaust air connection with canvas connection | <ul style="list-style-type: none"> 5 Butterfly valve outdoor air with servo drive 6 Butterfly valve exhaust air with servo drive 7 Counterflow heat exchanger with bypass (optionally with enthalpy) 8 Condensate tray heat exchanger with condensate drain Ø 32 mm | <ul style="list-style-type: none"> 9 Supply air fan 10 Exhaust air fan 11 Controller 12 Cable entries 13 Main switch 14 Bypass flap with servo motor 15 Outdoor air filter | <ul style="list-style-type: none"> 16 Extract filter 17 Pre-heater battery 18 Cable duct |
|---|---|---|---|



LG 1800 K WF/DINT

	T version	F version
Supply air volume [m³/h]		
<i>V_{rated}</i>	1500	1500
<i>V_{min}</i>	700	800
<i>V_{max}</i>	2300	2300
Dimensions (L x H x D) [mm]	2300 x 1390 x 1210	
Weight [kg]	~700	
Panel wall thickness [mm]	100	
Duct connection (w x h) [mm]	880 x 410 P30 720 x 270 for sliding type fittings (SUP/ETA in the case of units integrated into the roof)	
Fan type	EC	
Maximum power consumption [W]	1720 (without heater battery)	
Heat exchanger type	Counterflow heat exchanger	Enthalpy counterflow heat exchanger
Moisture transfer rate [%]		71.3
Thermal transfer rate dry [%]	85.2	79.3
Specific fan power, validation SFPv [Wh/m³]	0.33	0.35
Power consumption, validation [W]	495	525
Standard filter classes (outdoor air/extract air)	ePM1 55% / ePM10 75%	

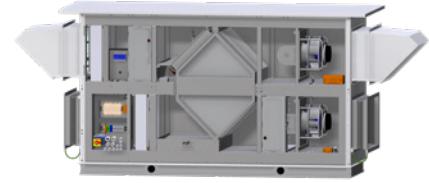

DESIGN DRAWING (RIGHT-HAND VERSION)

Caution: Drawing not true to scale. See underlined dimensions.

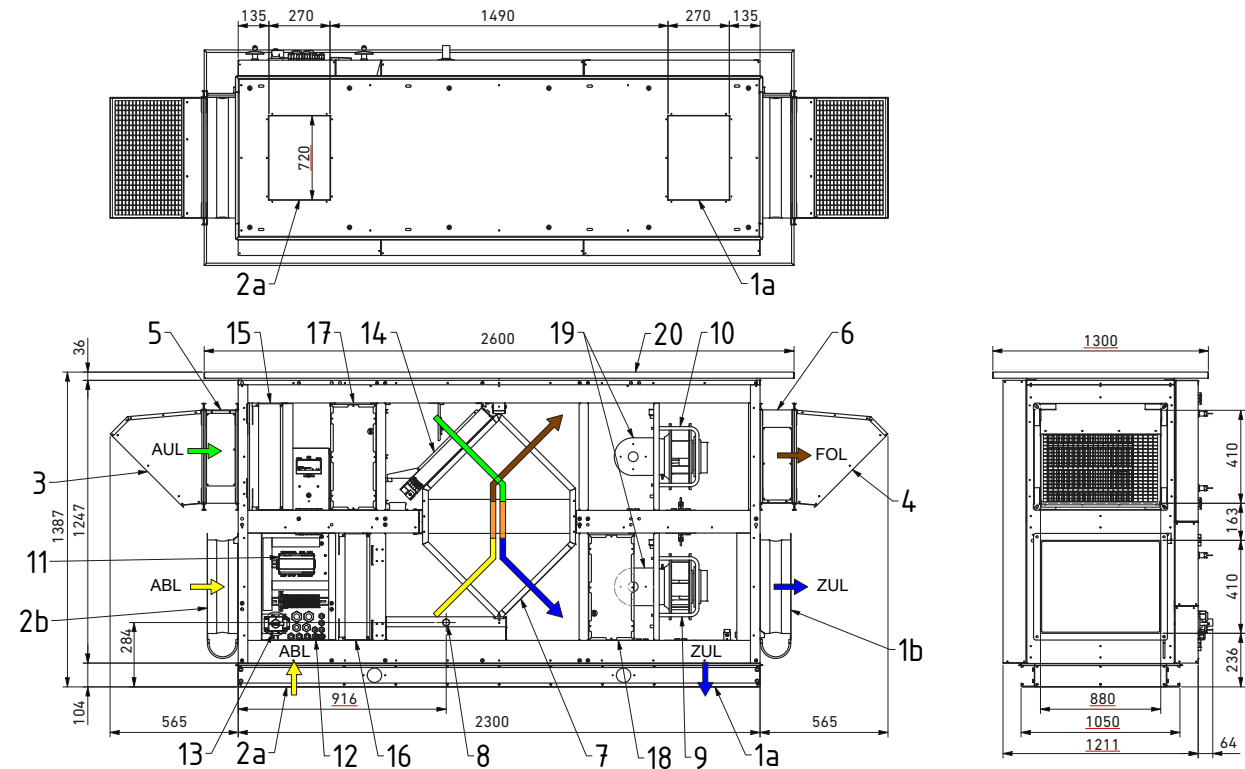

- 1a Supply air connection roof-integrated version for sliding type fittings
- 1b Supply air connection weather-proof version with canvas connection
- 2a Extract air connection roof-integrated version for sliding type fittings
- 2b Extract air connection weather-proof version with canvas connection
- 3 Outdoor air connection with hood
- 4 Exhaust air connection with hood
- 5 Butterfly valve outdoor air with servo drive
- 6 Butterfly valve exhaust air with servo drive
- 7 Counterflow heat exchanger with bypass (optional enthalpy)
- 8 Condensate tray heat exchanger with condensate drain Ø 32 mm
- 9 Supply air fan
- 10 Exhaust air fan
- 11 Controller
- 12 Cable entries
- 13 Main switch
- 14 Bypass flap with servo motor
- 15 Outdoor air filter
- 16 Extract filter
- 17 Pre-heater battery
- 18 Post-heater battery
- 19 Duct smoke detector
- 20 Unit roof



LG 1800 KN WF/DINT

	T version	F version
Supply air volume [m³/h]		
V_{rated}	1700	1700
V_{min}	700	800
V_{max}	2400	2300
Dimensions (L x H x D) [mm]	3890 x 1080 x 1470	
Weight [kg]	~1050	
Panel wall thickness [mm]	100	
Duct connection (w x h) [mm]	454 x 506 P30 (SUP/ETA with weather-proof units) 454 x 506 for sliding type fittings (SUP/ETA with roof-integrated units) 400 x 600 P30 (ODA/EHA)	
Fan type	EC	
Maximum power consumption [W]	1720 (without heater battery)	
Heat exchanger type	Counterflow heat exchanger	Enthalpy counterflow heat exchanger
Moisture transfer rate [%]		67.8
Thermal transfer rate dry [%]	85	77.4
Specific fan power, validation SFPv [Wh/m³]	0.37	0.38
Power consumption, validation [W]	629	646
Standard filter classes (outdoor air/extract air)	ePM1 55% / ePM10 75%	



DESIGN DRAWING (LEFT-HAND VERSION)

Caution: Drawing not true to scale. See underlined dimensions.

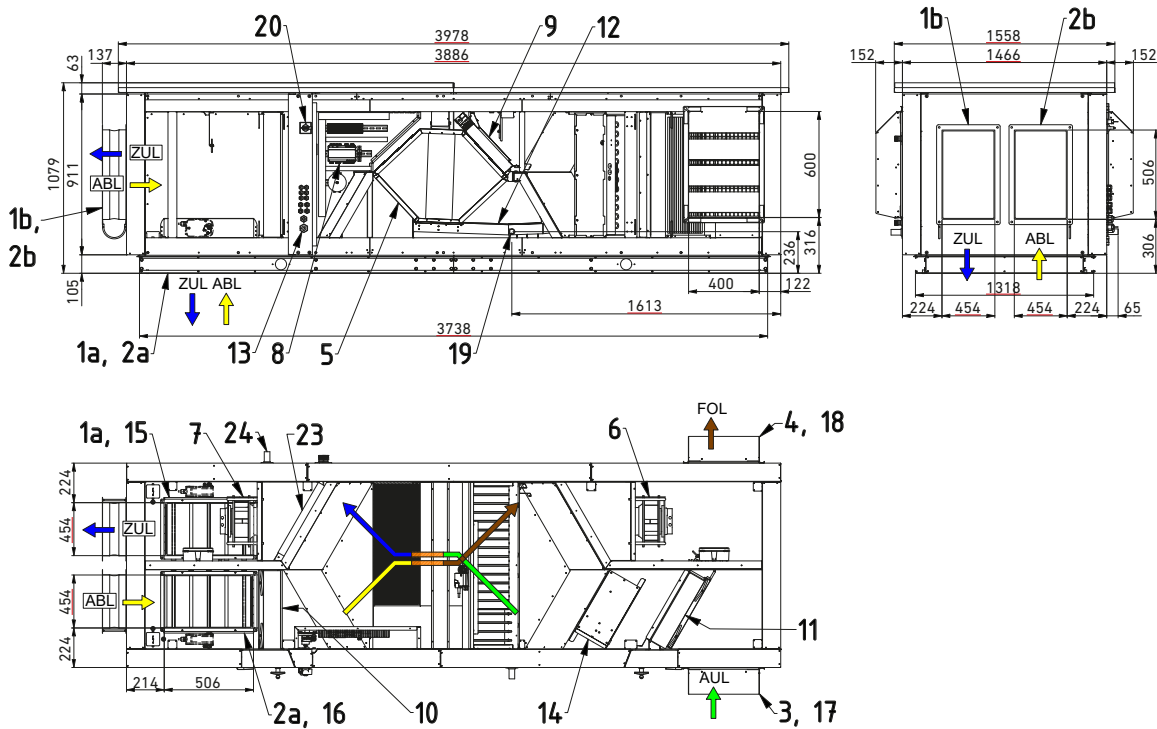

- 1a Supply air connection roof-integrated version for sliding type fittings
- 1b Supply air connection weather-proof version with canvas connection
- 2a Extract air connection roof-integrated version for sliding type fittings
- 2b Extract air connection weather-proof version with canvas connection
- 3 Outdoor air 400 x 600 mm
- 4 Exhaust air 400 x 600 mm
- 5 Counterflow heat exchanger with bypass (optional enthalpy)
- 6 Exhaust air fan
- 7 Supply air fan
- 8 Controller
- 9 Bypass flap with servo motor
- 10 Extract air filter
- 11 Outdoor air filter
- 12 Condensate tray heat exchanger
- 13 Cable entries 1 x M32, 1 x M25, 4 x M20, 6 x M16
- 14 Electric pre-heater battery
- 15 Butterfly valve supply air with servo drive (optional)
- 16 Butterfly valve extract air with servo drive (optional)
- 17 Outdoor air hood (with optional duct connection)
- 18 Exhaust air hood (with optional duct connection)
- 19 Condensate drain heat exchanger Ø 32 mm
- 20 Main switch
- 21 Canvas connection supply air P30 (optional)
- 22 Canvas connection extract air P30 (optional)
- 23 Combi heater water, heating, cooling (KOW, optional)
- 24 Condensate drain combi heater Ø 32 mm (KOW, optional)



LG 2500 IN

	T version	F version
Supply air volume [m³/h]		
V_{rated}	1700	1700
V_{min}	900	1000
V_{max}	2300	2300
Dimensions (L x H x D) [mm]	2900 x 1680 x 960	
Weight [kg]	~750	
Panel wall thickness [mm]	50	
Duct connection (w x h) [mm]	730 x 650 P30	
Fan type	EC	
Maximum power consumption [W]	2900 (without heater battery)	
Heat exchanger type	Counterflow heat exchanger	Enthalpy counterflow heat exchanger
Moisture transfer rate [%]		74
Thermal transfer rate dry [%]	85.1	80.3
Specific fan power, validation SFPv [Wh/m³]	0.33	0.34
Power consumption, validation [W]	561	578
Standard filter classes (outdoor air/extract air)	ePM1 55% / ePM10 75%	



DESIGN DRAWING (RIGHT-HAND VERSION)

Caution: Drawing not true to scale. See underlined dimensions.

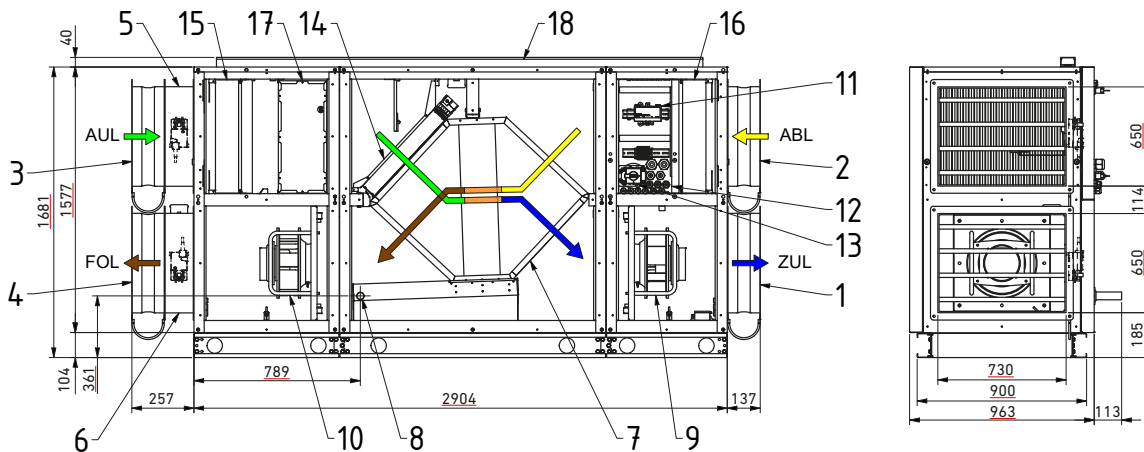

- 1 Supply air connection with canvas connection
- 2 Extract air connection with canvas connection
- 3 Outdoor air connection with canvas connection
- 4 Exhaust air connection with canvas connection
- 5 Butterfly valve outdoor air with servo drive
- 6 Butterfly valve exhaust air with servo drive
- 7 Counterflow heat exchanger with bypass (optional enthalpy)
- 8 Condensate tray heat exchanger with condensate drain \varnothing 32 mm
- 9 Supply air fan
- 10 Exhaust air fan
- 11 Controller
- 12 Cable entries
- 13 Main switch
- 14 Bypass flap with servo motor
- 15 Outdoor air filter
- 16 Extract filter
- 17 Pre-heater battery
- 18 Cable duct



LG 2500 WF/DINT

	T version	F version
Supply air volume [m³/h]		
V _{rated}	1700	1700
V _{min}	900	1000
V _{max}	2300	2300
Dimensions (L x H x D) [mm]	2900 x 1870 x 1060	
Weight [kg]	~1000	
Panel wall thickness [mm]	100	
Duct connection (w x h) [mm]	730 x 650 P30 570 x 370 for sliding type fittings (SUP/ETA in the case of units integrated into the roof)	
Fan type	EC	
Maximum power consumption [W]	2900 (without heater battery)	
Heat exchanger type	Counterflow heat exchanger	Enthalpy counterflow heat exchanger
Moisture transfer rate [%]		74
Thermal transfer rate dry [%]	85.1	80.3
Specific fan power, validation SFPv [Wh/m³]	0.33	0.34
Power consumption, validation [W]	561	578
Standard filter classes (outdoor air/extract air)	ePM1 55% / ePM10 75%	

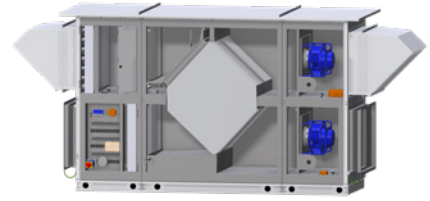

DESIGN DRAWING (RIGHT-HAND VERSION)

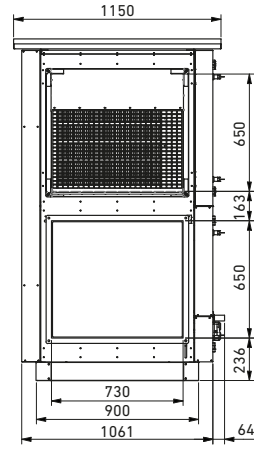
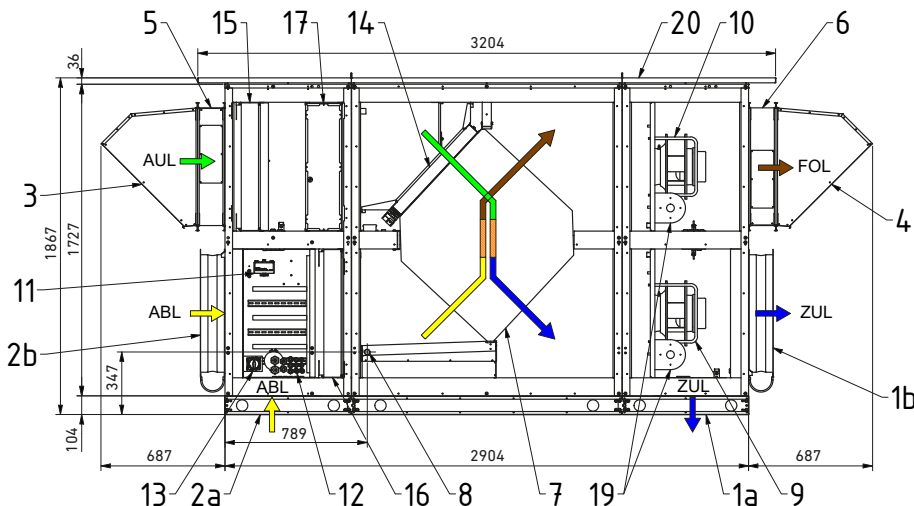
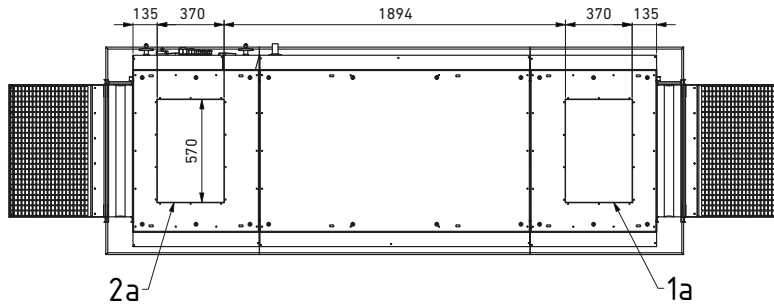

- 1a Supply air connection roof-integrated version for sliding type fittings
- 1b Supply air connection weather-proof version with canvas connection
- 2a Extract air connection roof-integrated version for sliding type fittings

- 2b Extract air connection weather-proof version with canvas connection
- 3 Outdoor air connection with hood
- 4 Exhaust air connection with hood
- 5 Butterfly valve outdoor air with servo drive
- 6 Butterfly valve exhaust air with servo drive

- 7 Counterflow heat exchanger with bypass (optional enthalpy)
- 8 Condensate tray heat exchanger with condensate drain Ø 32 mm
- 9 Supply air fan
- 10 Exhaust air fan
- 11 Controller
- 12 Cable entries

- 13 Main switch
- 14 Bypass flap with servo motor
- 15 Outdoor air filter
- 16 Extract air filter
- 17 Pre-heater battery
- 19 Duct smoke detector
- 20 Unit roof



LG 2500 N WF/DINT

	T version	F version
Supply air volume [m³/h]		
V _{rated}	2400	2400
V _{min}	1000	1100
V _{max}	3500	3500
Dimensions (L x H x D) [mm]	4490 x 1080 x 1960	
Weight [kg]	~1500	
Panel wall thickness [mm]	100	
Duct connection (w x h) [mm]	700 x 506 P30 (supply air/extract air with weather-proof units) 700 x 506 for sliding type fittings (supply air/extract air with roof-integrated units) 628 x 600 P30 (outdoor air/exhaust air)	
Fan type	EC	
Maximum power consumption [W]	2900 (without heater battery)	
Heat exchanger type	Counterflow heat exchanger	Enthalpy counterflow heat exchanger
Moisture transfer rate [%]		67.7
Thermal transfer rate dry [%]	85	77.2
Specific fan power, validation SFPv [Wh/m³]	0.34	0.35
Power consumption, validation [W]	816	840
Standard filter classes (outdoor air/extract air)	ePM1 55% / ePM10 75%	

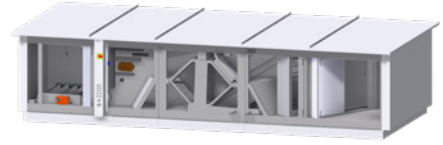

DESIGN DRAWING (LEFT-HAND VERSION)

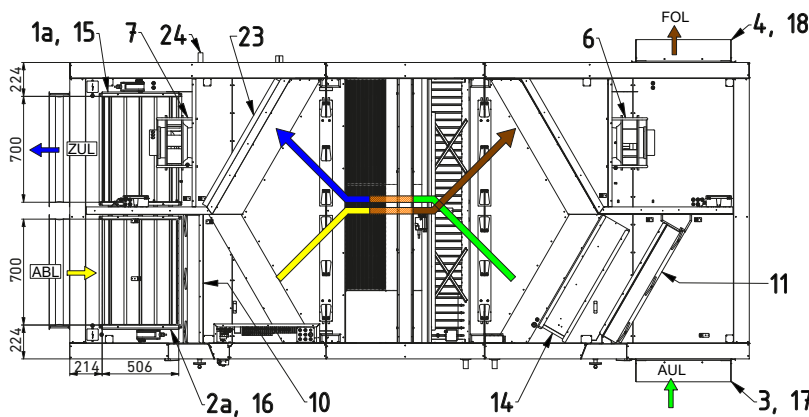
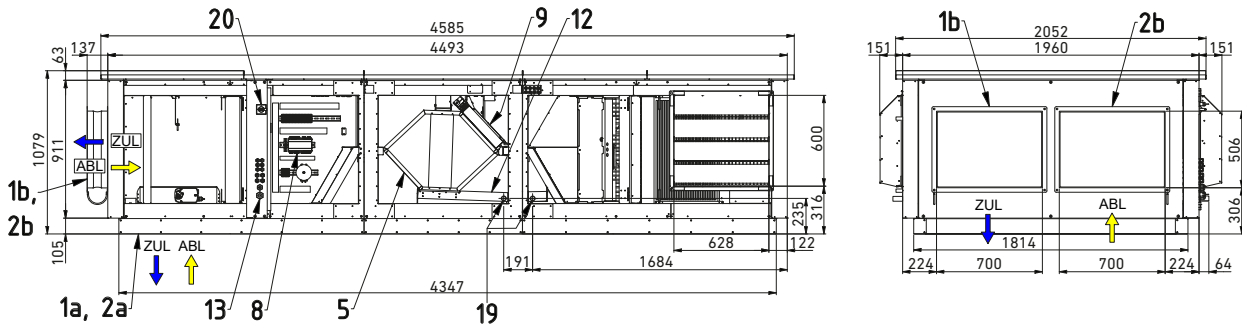

- 1a Supply air connection roof-integrated version for sliding type fittings
- 1b Supply air connection weather-proof version with canvas connection
- 2a Extract air connection roof-integrated version for sliding type fittings
- 2b Extract air connection weather-proof version with canvas connection
- 3 Outdoor air 628 x 600 mm

- 4 Exhaust air 628 x 600 mm
- 5 Counterflow heat exchanger with bypass (optional enthalpy)
- 6 Exhaust air fan
- 7 Supply air fan
- 8 Controller
- 9 Bypass flap with servo motor
- 10 Extract air filter
- 11 Outdoor air filter

- 12 Condensate tray heat exchanger
- 13 Cable entries 1 x M32, 1 x M25, 4 x M20, 6 x M16
- 14 Electric pre-heater battery
- 15 Butterfly valve supply air with servo drive (optional)
- 16 Butterfly valve extract air with servo drive (optional)
- 17 Outdoor air hood (with optional duct connection)

- 18 Exhaust air hood (with optional duct connection)
- 19 Condensate drain heat exchanger Ø 32 mm (2x)
- 20 Main switch
- 21 Canvas connection supply air P30 (optional)
- 22 Canvas connection extract air P30 (optional)
- 23 Combi heater water, heating, cooling (KOW, optional)
- 24 Condensate drain combi heater Ø 32 mm (KOW, optional)



LG 3200

	T version	F version
Supply air volume [m³/h]		
V _{rated}	1700	1700
V _{min}	900	1000
V _{max}	3200	2900
Dimensions (L x H x D) [mm]	2040 x 1660 x 960	
Weight [kg]	~390	
Panel wall thickness [mm]	50	
Duct connection (w x h) [mm]	300 x 800 P30 486 x 786 P30 (SUP/EHA for units with lateral connections)	
Fan type	EC	
Maximum power consumption [W]	2900 (without heater battery)	
Heat exchanger type	Counterflow heat exchanger	Enthalpy counterflow heat exchanger
Moisture transfer rate [%]		74
Thermal transfer rate dry [%]	85.1	80.3
Specific fan power, validation SFPv [Wh/m³]	0.33	0.34
Power consumption, validation [W]	561	578
Standard filter classes (outdoor air/extract air)	ePM1 55% / coarse 90%	



DESIGN DRAWING (RIGHT-HAND VERSION)

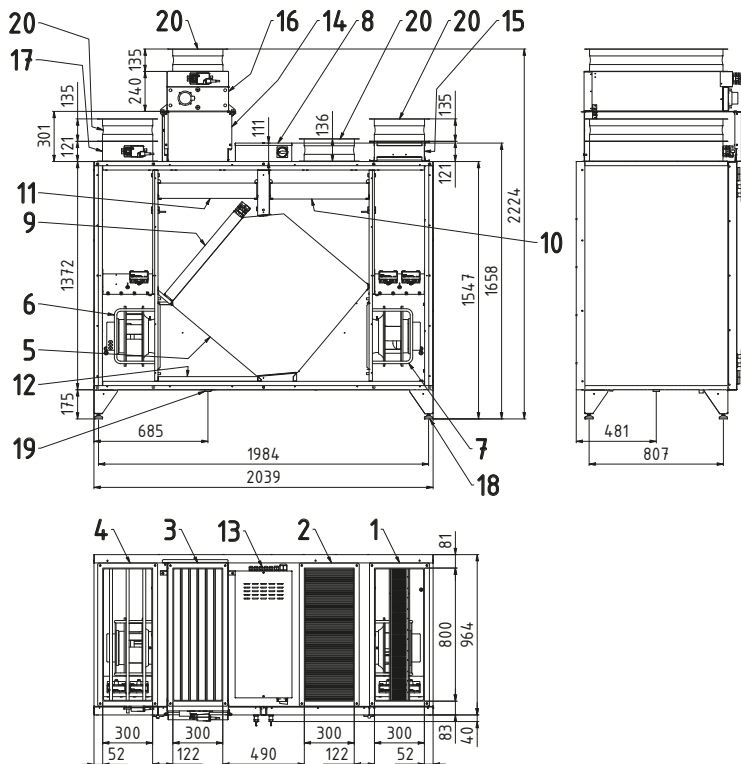

- | | | | |
|---|--|---|---|
| <p>1 Supply air 300 x 800 mm</p> <p>2 Extract air 300 x 800 mm</p> <p>3 Outdoor air 300 x 800 mm</p> <p>4 Exhaust air 300 x 800 mm</p> <p>5 Counterflow heat exchanger</p> <p>6 Exhaust air fan</p> <p>7 Supply air fan</p> <p>8 Controller</p> | <p>9 Bypass flap with servo motor</p> <p>10 Extract air filter</p> <p>11 Outdoor air filter</p> <p>12 Condensate tray</p> <p>13 Cable entries</p> <p>14 Electric pre-heater battery, with heat insulation (optional)</p> | <p>15 Electric post-heater battery (optional)</p> <p>16 Filter and flap box (required in connection with electric pre-heater battery) or butterfly valve supply air (optional, without electric pre-heater battery, 120 mm height)</p> <p>17 Butterfly valve exhaust air (optional)</p> | <p>18 Height-adjustable feet</p> <p>19 Condensate drain</p> <p>20 Elastic connectors on top</p> |
|---|--|---|---|



LG 4000 IN

	T version	F version
Supply air volume [m³/h]		
V_{rated}	2600	2600
V_{min}	1200	1300
V_{max}	4400	4300
Dimensions (L x H x D) [mm]	2820 x 1500 x 1510	
Weight [kg]	~900	
Panel wall thickness [mm]	50	
Duct connection (w x h) [mm]	1280 x 560 P30	
Fan type	EC	
Maximum power consumption [W]	5200 (without heater battery)	
Heat exchanger type	Counterflow heat exchanger	Enthalpy counterflow heat exchanger
Moisture transfer rate [%]		71.5
Thermal transfer rate dry [%]	85	78.9
Specific fan power, validation SFPv [Wh/m³]	0.3	0.32
Power consumption, validation [W]	780	832
Standard filter classes (outdoor air/extract air)	ePM1 55% / ePM10 75%	



DESIGN DRAWING (RIGHT-HAND VERSION)

Caution: Drawing not true to scale. See underlined dimensions.

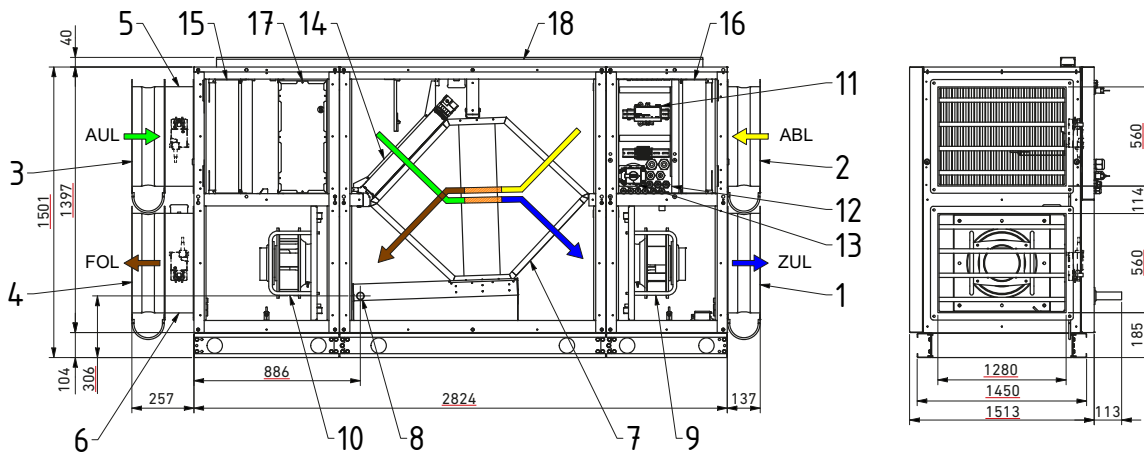

- 1 Supply air connection with canvas connection
- 2 Extract air connection with canvas connection
- 3 Outdoor air connection with canvas connection
- 4 Exhaust air connection with canvas connection
- 5 Butterfly valve outdoor air with servo drive
- 6 Butterfly valve exhaust air with servo drive
- 7 Counterflow heat exchanger with bypass (optional enthalpy)
- 8 Condensate tray heat exchanger with condensate drain \varnothing 32 mm"
- 9 Supply air fan
- 10 Exhaust air fan
- 11 Controller
- 12 Cable entries
- 13 Main switch
- 14 Bypass flap with servo motor
- 15 Outdoor air filter
- 16 Extract air filter
- 17 Pre-heater battery
- 18 Cable duct



LG 4000 WF/DINT

	T version	F version
Supply air volume [m³/h]		
V_{rated}	2600	2600
V_{min}	1200	1300
V_{max}	4400	4300
Dimensions (L x H x D) [mm]	2820 x 1690 x 1610	
Weight [kg]	~1200	
Panel wall thickness [mm]	100	
Duct connection (w x h) [mm]	1280 x 560 P30 1120 x 470 for sliding type fittings (SUPPLY AIR/EXTRACT AIR in the case of units integrated into the roof)	
Fan type	EC	
Maximum power consumption [W]	5200 (without heater battery)	
Heat exchanger type	Counterflow heat exchanger	Enthalpy counterflow heat exchanger
Moisture transfer rate [%]		71.5
Thermal transfer rate dry [%]	85	78.9
Specific fan power, validation SFPv [Wh/m³]	0.3	0.32
Power consumption, validation [W]	780	832
Standard filter classes (outdoor air/extract air)	ePM1 55% / ePM10 75%	

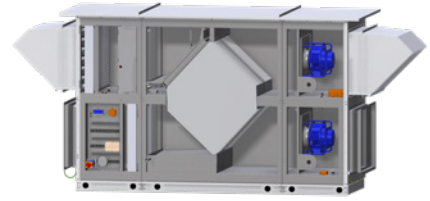

DESIGN DRAWING (RIGHT-HAND VERSION)

Caution: Drawing not true to scale. See underlined dimensions.

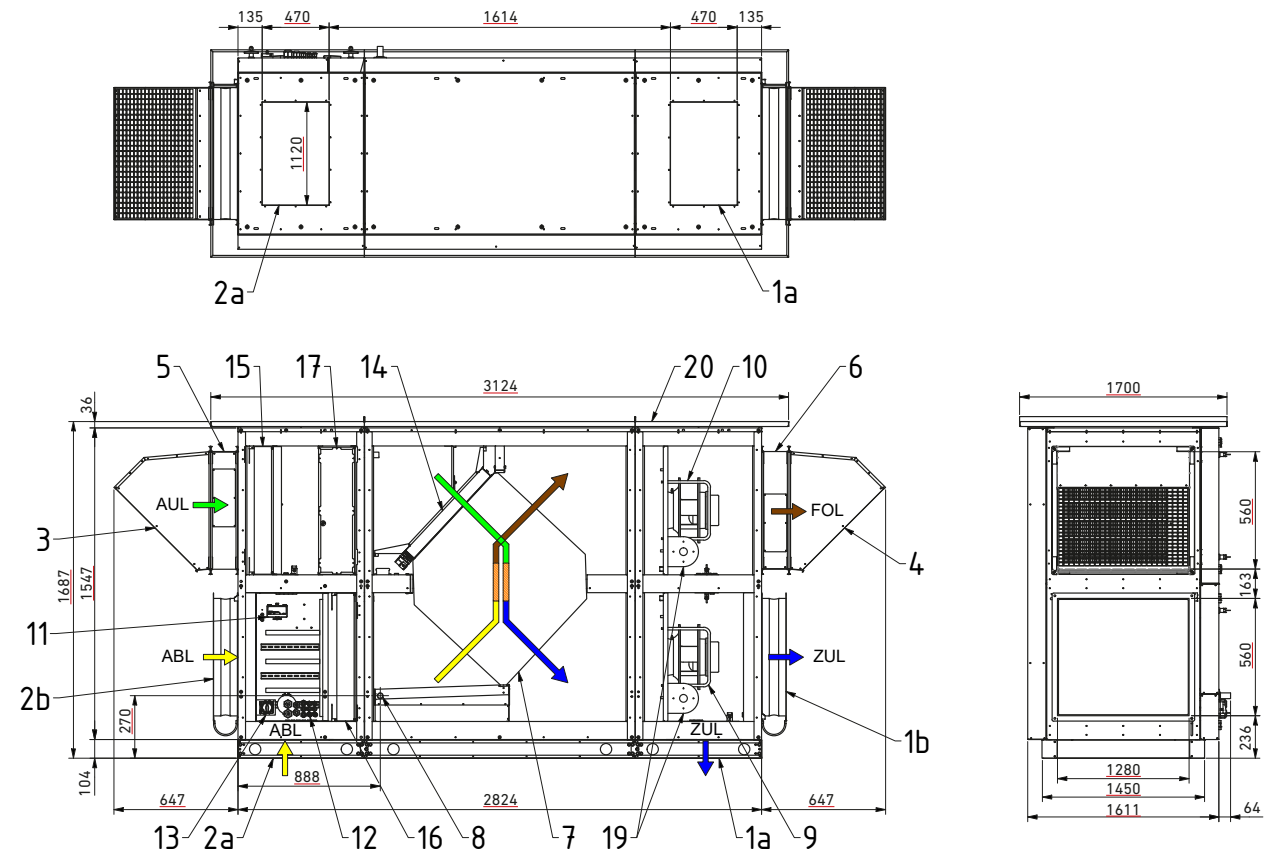

- 1a Supply air connection roof-integrated version for sliding type fittings
- 1b Supply air connection weather-proof version with canvas connection
- 2a Extract air connection roof-integrated version for sliding type fittings

- 2b Extract air connection weather-proof version with canvas connection
- 3 Outdoor air connection with hood
- 4 Exhaust air connection with hood
- 5 Butterfly valve outdoor air with servo drive
- 6 Butterfly valve exhaust air with servo drive

- 7 Counterflow heat exchanger with bypass (optional enthalpy)
- 8 Condensate tray heat exchanger with condensate drain Ø 32 mm
- 9 Supply air fan
- 10 Exhaust air fan
- 11 Controller

- 12 Cable entries
- 13 Main switch
- 14 Bypass flap with servo motor
- 15 Outdoor air filter
- 16 Extract air filter
- 17 Pre-heater battery
- 19 Duct smoke detector
- 20 Unit roof



LG 6000 IN

	T version
Supply air volume [m³/h]	
V_{rated}	6300
V_{min}	2500
V_{max}	7800
Dimensions (L x H x D) [mm]	3400 x 2080 x 2010
Weight [kg]	~1650
Panel wall thickness [mm]	50
Duct connection (w x h) [mm]	1780 x 851 P30
Fan type	EC
Maximum power consumption [W]	4200 (without heater battery)
Heat exchanger type	Counterflow heat exchanger
Moisture transfer rate [%]	
Thermal transfer rate dry [%]	85
Specific fan power, validation SFPv [Wh/m³]	0.33
Power consumption, validation [W]	2079
Standard filter classes (outdoor air/extract air)	ePM1 55% / ePM10 75%



DESIGN DRAWING (RIGHT-HAND VERSION)

Caution: Drawing not true to scale. See underlined dimensions.

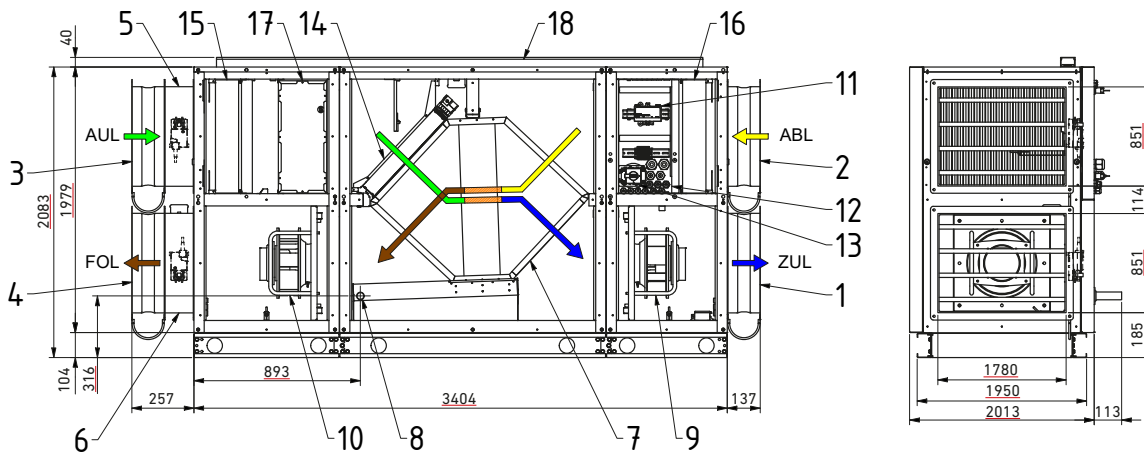

- 1 Supply air connection with canvas connection
- 2 Extract air connection with canvas connection
- 3 Outdoor air connection with canvas connection
- 4 Exhaust air connection with canvas connection
- 5 Butterfly valve outdoor air with servo drive
- 6 Butterfly valve exhaust air with servo drive
- 7 Counterflow heat exchanger with bypass (optional enthalpy)
- 8 Condensate tray heat exchanger with condensate drain \varnothing 32 mm
- 9 Supply air fan
- 10 Exhaust air fan
- 11 Controller
- 12 Cable entries
- 13 Main switch
- 14 Bypass flap with servo motor
- 15 Outdoor air filter
- 16 Extract air filter
- 17 Pre-heater battery
- 18 Cable duct



LG 6000 WF/DINT

	T version
Supply air volume [m³/h]	
V _{rated}	6300
V _{min}	2500
V _{max}	7800
Dimensions (L x H x D) [mm]	3400 x 2270 x 2110
Weight [kg]	~2100
Panel wall thickness [mm]	100
Duct connection (w x h) [mm]	1780 x 851 P30 1620 x 470 for sliding type fittings (SUPPLY AIR/EXTRACT AIR in the case of units integrated into the roof)
Fan type	EC
Maximum power consumption [W]	4200 (without heater battery)
Heat exchanger type	Counterflow heat exchanger
Moisture transfer rate [%]	
Thermal transfer rate dry [%]	85
Specific fan power, validation SFPv [Wh/m³]	0.33
Power consumption, validation [W]	2079
Standard filter classes (outdoor air/extract air)	ePM1 55% / ePM10 75%

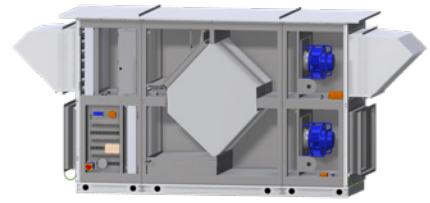

DESIGN DRAWING (RIGHT-HAND VERSION)

Caution: Drawing not true to scale. See underlined dimensions.

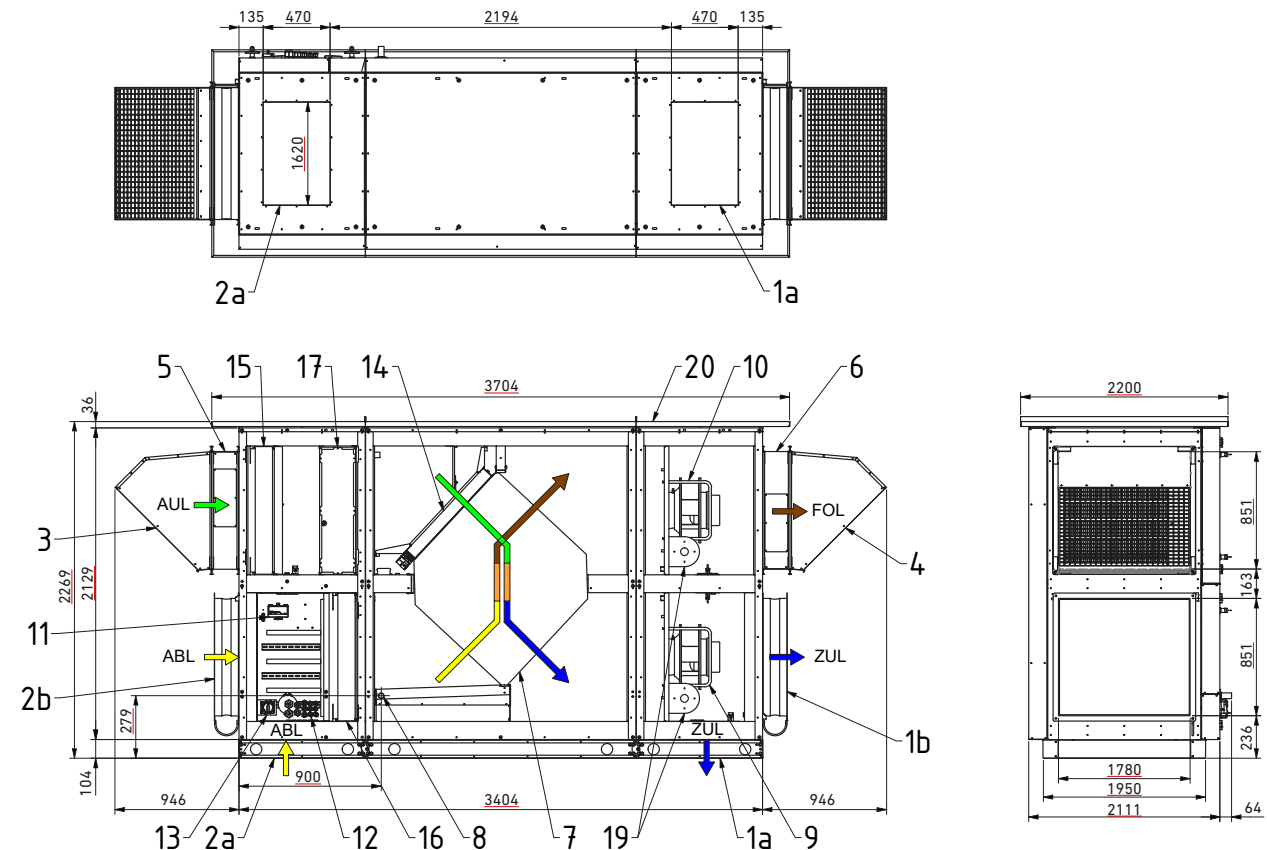

- 1a Supply air connection roof-integrated version for sliding type fittings
- 1b Supply air connection weather-proof version with canvas connection
- 2a Extract air connection roof-integrated version for sliding type fittings

- 2b Extract air connection weather-proof version with canvas connection
- 3 Outdoor air connection with hood
- 4 Exhaust air connection with hood
- 5 Butterfly valve outdoor air with servo drive
- 6 Butterfly valve exhaust air with servo drive

- 7 Counterflow heat exchanger with bypass (optional enthalpy)
- 8 Condensate tray heat exchanger with condensate drain Ø 32 mm
- 9 Supply air fan
- 10 Exhaust air fan
- 11 Controller

- 12 Cable entries
- 13 Main switch
- 14 Bypass flap with servo motor
- 15 Outdoor air filter
- 16 Extract air filter
- 17 Pre-heater battery
- 19 Duct smoke detector
- 20 Unit roof



PICHLER system components

As a specialized supplier, our company PICHLER provides individually tailored ventilation technology solutions. Whether your project involves private or commercial buildings, or facilities from the educational sector, our employees will give you comprehensive counselling and support you in implementing the solution that is perfectly tailored to your needs. Our complete systems are used for both new construction and renovation. They are highly efficient and extra quiet, and they work fully automatically, user-friendly and, upon your request, can be monitored via remote access.

PICHLER products offer you maximum energy efficiency. Our components and parts are carefully matched and ensure economic operation of your system. Furthermore, heat recovery itself already allows you to save a considerable amount of energy and heating costs. Energy consumption drops, and sustainability increases.



PICHLER



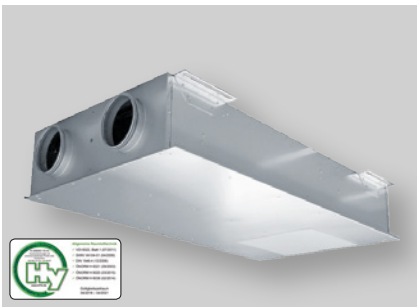

VAV USD box



Living space controller

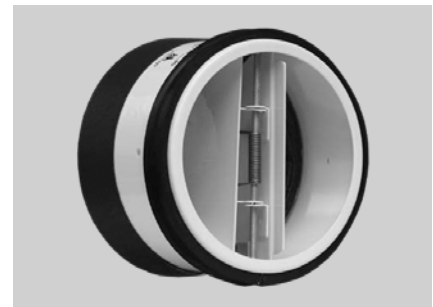

Fire protection closure

PICHLER components and accessories

Pichler is your partner for competent and complete ventilation systems. We offer you all ventilation units, components and all accessories for

your ventilation project, from air distribution to air regulation, including air conduction, and from the air duct system to the smallest screw, including

fire protection flaps. Refer to the technical documentation for details on our range of components.

PICHLER COMPONENTS		
COMFORT VENTILATION	AIR CONDUCTION	AIR DISTRIBUTION
AIR QUALITY SENSORS (ROOM TEMPERATURE, CO ₂ & HUMIDITY FOR CUSTOMIZED VENTILATION)	SOUND DAMPERS PVSR-USD, USD, PFSD	AIR OUTLETS (VALVES, DESIGN VALVES)
TOUCH SCREEN (OPTIONAL CONTROL UNIT)	VAV USD BOX FOR SUPPLY AND EXTRACT AIR	
PRE- AND POST-HEATER BATTERIES, COOLING BATTERY	FLOW REGULATOR	
BUILDING AUTOMATION – NETWORKABILITY	DISTRIBUTION SYSTEMS (KOMFLEX ROUND OR OVAL, SYSTEM SAFE)	
	SUCTION AND BLOW-OUT ELEMENTS	
	COMPONENTS FOR STRUCTURAL FIRE PROTECTION	





PICHLER original filters

Unit	Description		Required quantity	Article number
ERG60	ODA-FILTER ISO EPM2,5 50%	Outdoor air	1	08ERG60KASF7
ERG60	ETA-FILTER ISO COARSE 50%	Extract air	1	08ERG60KASG4
LG100	ODA/ETA-FILTER ISO COARSE 70%	Outdoor air	1	40LG0500006A
LG100	ODA/ETA-FILTER ISO COARSE 70%	Extract air	1	40LG0500006A
LG100	SUP-FILTER ISO EPM1 55%	Supply air	1	40LG0500007A
LG150	ODA-FILTER ISO EPM2,5 55%	Outdoor air	1	40LG050230
LG150	ETA-FILTER ISO COARSE 70%	Extract air	1	40LG050240
LG150	ODA-FILTER ISO EPM1 80%	Opt. outdoor air pollen filter	1	40LG050250
LG180	ETA-FILTER ISO COARSE 70%	Extract air	1	40LG050020
LG180	ODA-FILTER ISO EPM2,5 55%	Outdoor air	1	40LG050040
LG180	ETA-FILTER ISO EPM10 75%	Opt. extract air filter	1	40LG050010
LG180	ODA-FILTER ISO EPM1 80%	Opt. outdoor air pollen filter	1	40LG050030
LG180	MATTENFILTER ISO COARSE 60%	PTC preheater battery spare filter	1	40LG080031
LG250	ETA-FILTER ISO COARSE 90%	Extract air	1	40LG050050
LG250	ODA-FILTER ISO EPM1 55%	Outdoor air	1	40LG050060
LG250	ODA-FILTER ISO EPM1 80%	Opt. outdoor air pollen filter	1	40LG050070
LG250	ETA-FILTER ISO EPM10 75%	Opt. extract air filter	1	40LG050080
LG350/450	ETA-FILTER ISO COARSE 80%	Extract air	1	40LG0500000A
LG350/450	ODA-FILTER ISO EPM1 60%	Outdoor air	1	40LG0500001A
LG500P	ODA-FILTER ISO EPM2,5 65%	Outdoor air	1	40LG050090
LG500P	ETA-FILTER ISO COARSE 70%	Extract air	1	40LG050100
LG500P	ODA-FILTER ISO EPM1 80%	Opt. outdoor air pollen filter	1	40LG050110
LG500P	ETA-FILTER ISO COARSE 80%	Opt. extract air filter	1	40LG050120
AWP600	ETA-FILTER ISO EPM10 75%	Extract air	1	40LG050380
PKOM	ODA-FILTER ISO EPM1 55%	Outdoor air	1	40LG050290
PKOM	ETA-FILTER ISO EPM10 75%	Extract air	1	40LG050280
LG740	ODA-FILTER ISO EPM1 55%	Outdoor air	1	40LG0500024A
LG740	ETA-FILTER ISO COARSE 70%	Extract air	1	40LG0500025A
LG750T	ODA-FILTER ISO EPM1 55%	Outdoor air	1	40LG0500013A
LG750	ETA-FILTER ISO EPM10 75%	Extract air	1	40LG050300
LG750	ODA-FILTER ISO EPM2,5 55%	Outdoor air	1	40LG050310
LG750	AKTIVKOHLEFILTER EPM1 55%	Opt. outdoor air activated carbon filter	1	08LG07AKF592402
LG900KNDE	ODA-FILTER ISO EPM1 55%	Outdoor air	1	40LG0500022A
LG900KNDE	ETA-FILTER ISO EPM10 75%	Extract air	1	40LG0500023A
LG1000	ODA-FILTER ISO EPM2,5 55%	Outdoor air	1	40LG050270
LG1000T	ODA-FILTER ISO EPM1 55%	Outdoor air	1	40LG0500014A
LG1000	ETA-FILTER ISO EPM10 75%	Extract air	1	40LG050260
LG1000	AKTIVKOHLEFILTER EPM1 55%	Opt. outdoor air activated carbon filter	1	08LG10AKF645467
CAS1000	MATTENFILTER ISO COARSE 60%	Supply air level 1		40LG0500008A
CAS1000	FILTERZELLE ISO EPM1 55%	Supply air level 2	1	40LG0500009A
CAS1000	SCHWEBSTOFFFILTER H14	Supply air level 3	1	40LG0500010A



Unit	Description		Required quantity	Article number
LG1000SKD	ODA-FILTER ISO EPM1 55%	Outdoor air	1	40LG0500026A
LG1000SKD	ETA-FILTER ISO EPM10 75%	Extract air	1	40LG0500027A
LG1000SKS	ODA-FILTER ISO EPM1 55%	Outdoor air	1	40LG0500026A
LG1000SKS	ETA-FILTER ISO EPM10 75%	Extract air	1	40LG050300
LG1000KN	ODA-FILTER ISO EPM1 55%	Outdoor air	1	40LG0500004A
LG1000KN	ETA-FILTER ISO EPM10 75%	Extract air	1	40LG0500003A
LG1400	ETA-FILTER ISO COARSE 90%	Extract air	1	40LG050140
LG1400	ODA-FILTER ISO EPM1 55%	Outdoor air	1	40LG050130
LG1400	MATTENFILTER ISO COARSE 70%	Prefilter box VFBG spare filter	1	08EFG4183595
LG1400	ODA-VORFILTER ISO COARSE 70%	Prefilter box FFK spare filter	1	40LG0500020A
LG1400	ODA-FILTER ISO EPM1 85%	Opt. outdoor air pollen filter	1	40LG050150
LG1400	ETA-FILTER ISO EPM10 70%	Opt. extract air	1	40LG050160
LG1800T	ODA-FILTER ISO EPM1 55%	Outdoor air	1	40LG0500011A
LG1800T	ETA-FILTER ISO EPM10 75%	Extract air	1	40LG0500012A
LG1800KN	ODA-FILTER ISO EPM1 55%	Outdoor air	1	40LG0500018A
LG1800KN	ETA-FILTER ISO EPM10 75%	Extract air	1	40LG0500019A
LG2500	ODA-FILTER ISO EPM2,5 55%	Outdoor air	1	40LG050330
LG2500T	ODA-FILTER ISO EPM1 55%	Outdoor air	1	40LG0500015A
LG2500	ETA-FILTER ISO EPM10 75%	Extract air	1	40LG050320
LG2500N	ODA-FILTER ISO EPM1 55%	Outdoor air	1	40LG0500015A
LG2500N	ETA-FILTER ISO EPM10 75%	Extract air	1	40LG050320
LG3200	ODA-FILTER ISO EPM1 55%	Outdoor air	1	40LG050170
LG3200	ETA-FILTER ISO COARSE 90%	Extract air	1	40LG050180
LG3200	MATTENFILTER ISO COARSE 70%	Prefilter box VFBG spare filter	1	08EFG4283795
LG3200	ODA-FILTER ISO EPM1 85%	Opt. outdoor air pollen filter	1	40LG050190
LG3200	ETA-FILTER ISO EPM10 70%	Opt. extract air	1	40LG050200
LG3200	ODA-VORFILTER ISO COARSE 70%	Prefilter box FFK spare filter	1	40LG0500021A
LG4000	ODA-FILTER ISO EPM2,5 55%	Outdoor air	2	40LG050350
LG4000T	ODA-FILTER ISO EPM1 55%	Outdoor air	2	40LG0500016A
LG4000	ETA-FILTER ISO EPM10 75%	Extract air	2	40LG050340
LG6000	ODA-FILTER ISO EPM2,5 55%	Outdoor air	3	40LG050370
LG6000T	ODA-FILTER ISO EPM1 55%	Outdoor air	3	40LG0500017A
LG6000	ETA-FILTER ISO EPM10 75%	Extract air	3	40LG050360



Complete solutions

With our extensive range of products we professionally cover all major fields of ventilation technology. We develop, design, produce and commission components and complete installations for new-builds and renovations. Reliable and in outstanding quality.

SUSTAINABLE PROJECTS FOR A HIGH QUALITY OF LIFE

- Comfort ventilation in residential construction
- Hotels & boarding houses
- Residential accommodations & care facilities
- Educational establishments such as kindergartens, schools, universities
- Offices, banks & insurance companies
- Spas & swimming pools
- Trade & catering
- Industrial & commercial plants



Notes



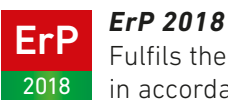

ErP 2018

Fulfills the requirements of the Ecodesign Directive,
in accordance with EU Regulation 1253/2014.



klimaaktiv
Partner

PASSIVHAUS
Austria

Mitglied
NETZWERK
PASSIVHAUS
www.passivhaus.at

Responsible for the content: J. Pichler Gesellschaft m.b.H. | Graphics and layout: WERK1 Werbegraphik GmbH
Photos: J. Pichler Gesellschaft m.b.H. | Text: J. Pichler Gesellschaft m.b.H.
All rights reserved | All photos are symbolic photos | Subject to change without notice | Version: 11/2025 en

PICHLER
Systematic ventilation.

J. PICHLER
Gesellschaft m.b.H.

AUSTRIA
9021 KLAGENFURT
AM WÖRTHERSEE
Karlweg 5
T +43 (0)463 32769

1100 WIEN
Doerenkampgasse 5
T +43 (0)1 6880988

office@pichlerluft.at
www.pichlerluft.at

PICHLER
Lüftungstechnik G.m.b.H

GERMANY
86825 BAD WÖRISHOFEN
Altwaterstraße 23
office@pichlerluft.de
www.pichlerluft.de

PICHLER & CO d.o.o.
prezračevalni sistemi

SLOVENIA
2000 MARIBOR
Cesta k Tamu 26
T +386 (0)2 46013-50
pichler@pichler.si
www.pichler.si

KLIMA DOP d.o.o.
klimatizacija i ventilacija

SERBIA
11070 NOVI BEOGRAD
Autoput Beograd-Zagreb
bb (Blok 52 – prostor GP
„Novi Kolektiv“)
T +381 (0)11 3190177
office@klimadop.com
www.klimadop.com